

Service
Service
Service

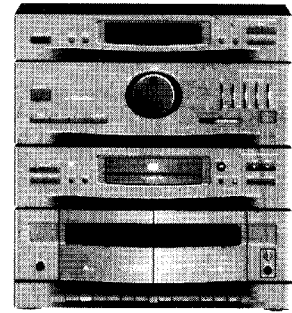

Service Manual



TABLE OF CONTENTS

Specification 2 - 3
 Measurement setup 4
 Safety 5
 Connections & Controls 6 - 7
 Service hints 8
 Dismantling Hints 9 - 11
 Service Testprogram 12 - 16
 Wiring Diagram of Set 17 - 18
 Block Diagram of Set 19 - 21
Front Board
 Component Layout copper side view 22 - 24
 Circuit Diagram AF-Part 25 - 26
 Component Layout component side view 27 - 28
 Circuit Diagram Control-Part 29 - 30
Recorder Board
 Adjustment Table 31
 Component Layout 32
 Circuit Diagram 33 - 34
Power Board
 Component Layout 35 - 36
 Circuit Diagram 37 - 38
Trafo Board
 Circuit Diagram 39
 Component Layout 39
ECO 4 Tuner
 Circuit Diagram 40 - 42
 Component Layout 43 - 44
 Adjustment Table 45
Micro Mix Board
 Component Layout 46
 Circuit Diagram 46 - 47

Spectrum Analyzer Board

Circuit Diagram 47 - 48
 Component Layout 48

CD

Block Diagram 49 - 50
 Component Layout 51 - 52
 Circuit Diagram 53 - 55
 Dismantling Hints CD Unit 56 - 58
 Exploded View CD 59 - 60
 Faultfinding Tree 61 - 62
 Abbreviations 63
 Exploded Views of Set 65 - 68
 Partslist 69 ff

Annex

- Service Manual** Tape Transport RDN-11
- Service Manual** Record Player DL-40



Specification

General:

Mains voltage	: 220V / 50Hz for /20, /22
	: 240V / 50Hz for /25
Power consumption	: ≤ 105 W at maximum output power
	: ≤ 10 W in stand by

Amplifier:

Output power	: 2 x 20W at 6Ω D=10%
Music power	: 2 x 60W at 6Ω
Headphone	: 6,3mm stereo jack 25mW at 32Ω (≈0,9V at 32Ω)

Power stage protection : Temperature

Frequency response	: 63 Hz - 14 kHz (-3dB) Limit
	: 63 Hz - 17 kHz (-3dB) Typical value

Tone control

DBB	: ±6dB at 100 Hz
300 Hz	: ±6dB at 300 Hz
1 kHz	: ±6dB at 1 kHz
4 kHz	: ±6dB at 4 kHz
10 kHz	: ±6dB at 10kHz

Input sensitivity	
PHONO/LINE	: 350 mV

Tuner:

	FM	MW	LW
Tuning range	37,5 - 108 MHz Grid 50 kHz	522 - 1611 kHz (Grid 9kHz) 530 - 1700 kHz (only for /37) (Grid 10kHz)	148 - 284 kHz (Grid 3kHz)
Aerial input	Coax F-Connector 75 Ω	Ferrite antenna	Ferrite antenna
IF	10,7 MHz ± 25 kHz	450 kHz ± 1 kHz	450 kHz ± 1 kHz
Sensitivity	Mono : 26dB S/N Stereo : 46dB S/N Search tuning	3 mV/m (1,5 mV/m typ.) ≤ 6mV/m	≤ 6 mV/m ≤ 6mV/m
Distortion	≤3% (2% typ.) RF=1mV Δf=75kHz	≤5% (3% typ) RF=100mV/m m=80%	≤5% (3% typ) RF=100mV/m m=80%
Channel separation	≥26dB (30dB typ)	-	-
Image rejection ratio	30 dB (40 dB typ.)	27 dB (30 dB typ.)	40 dB (43 dB typ.)
-3 dB limiting point	≤ 5 μV (2 μV typ.)		

CD unit: Have to be measured direct on internal connector 1300

Frequency response	: 20 - 20.000 Hz ±2 dB
Output level	: 2V ±3 dB
Signal/noise ratio	: ≥90 dB
Distortion	: ≤1% at 1 kHz
Channel difference	: ≤2 dB at 1 kHz
Channel crosstalk	: 50 dB max.
De emphasis	: 0 or 15/50 μs switched automatically by subcode on the disc

Laser

Output power	: ≤500 μW
Wave length	: 780 nm ± 20 nm

Tape speed	: 4,76 cm/s $\pm 2\%$ in Normal Speed : 8,5 cm/s $\pm 12\%$ in High Speed Dubbing	Power supply	: 12V DC / 80mA
Wow & Flutter	: $\leq 0,4\%$	Wow & Flutter	: 0,25% JIS : 0,35% DIN
Winding speed	: ≤ 130 s for C60 cassette	Operating speed	: 33 $\frac{1}{3}$ and 45 rpm
Erase / Bias system	: AC 88 kHz ± 4 kHz	Drive system	: Belt drive with automatic return
RIF-shift	: service solution on request		
Distortion at 200 nWb/m	: $\leq 5\%$		
Channel difference at PB	: ≤ 3 dB		
Channel difference overall	: ≤ 3 dB		
Channel separation	: ≥ 18 dB at 1kHz		
Track separation	: ≥ 55 dB at 1kHz		

	IEC I	IEC I (dubbing)	IEC II	IEC II (dubbing)
Frequency response -8 dB ¹⁾	100Hz - 12,5kHz	100Hz - 12,5kHz	100Hz - 12,5kHz	100Hz - 12,5kHz
Signal to Hiss ratio ²⁾ A-weighted	≥ 45 dB	≥ 45 dB	≥ 45 dB	≥ 45 dB
Signal to Noise ratio ²⁾ FF-weighted	≥ 40 dB	≥ 40 dB	≥ 40 dB	≥ 40 dB
Erase attenuation ³⁾	≥ 55 dB	≥ 55 dB	≥ 55 dB	≥ 55 dB

¹⁾ typical value

²⁾ at 250 nWb/m

³⁾ Use a 1 kHz passfilter to minimize the wide band noise component.

The set reacts on following RC5 commands:

	Systemcode	Commandcode
Stand by	17,20,21	12
Tuner	17	63
Aux/Phono	21	63
CD	20	63
Volume up	16	16
Volume down	16	17
Repeat	20	29
Shuffle	20	28
Scan	20	43
Play (CD)	20	53
Pause (CD)	20	48
Next (CD)	20	32
Previous (CD)	20	33
Search Forward (CD)	20	52
Search Backward (CD)	20	50
Stop (CD)	20	54
Tuning up	17	30
Tuning down	17	31
Preset up	17	32
Preset down	17	33

Measurement setup

Tuner FM

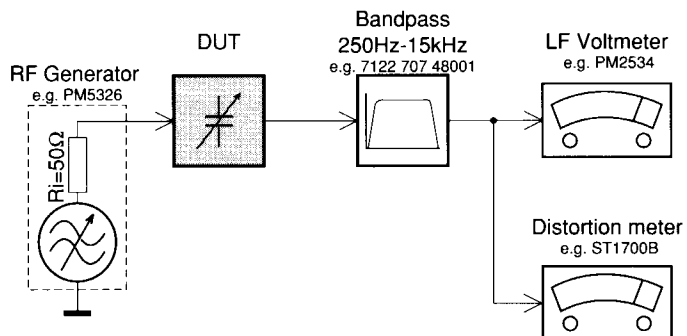

Use a bandpass filter to eliminate hum (50Hz, 100Hz) and disturbance from the pilotone (19kHz, 38kHz).

Tuner AM (MW,LW)

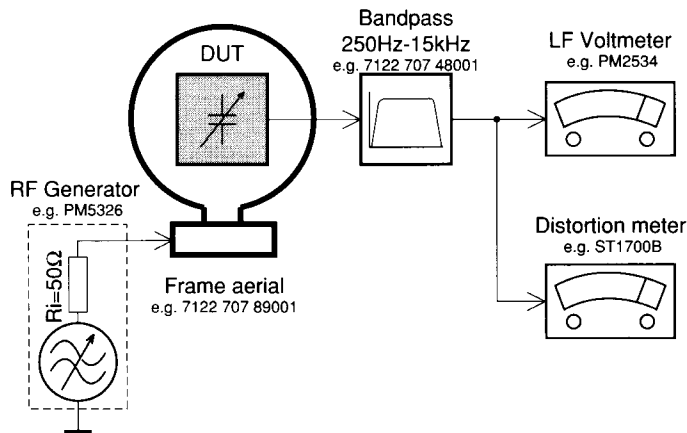

To avoid atmospheric interference all AM-measurements have to be carried out in a Faraday's cage. Use a bandpass filter (or at least a high pass filter with 250Hz) to eliminate hum (50Hz, 100Hz).

CD

Use Audio Signal Disc SBC429 4822 397 30184 (replaces test disc 3)
 L.P.F. = 13th order filter 4822 395 30204

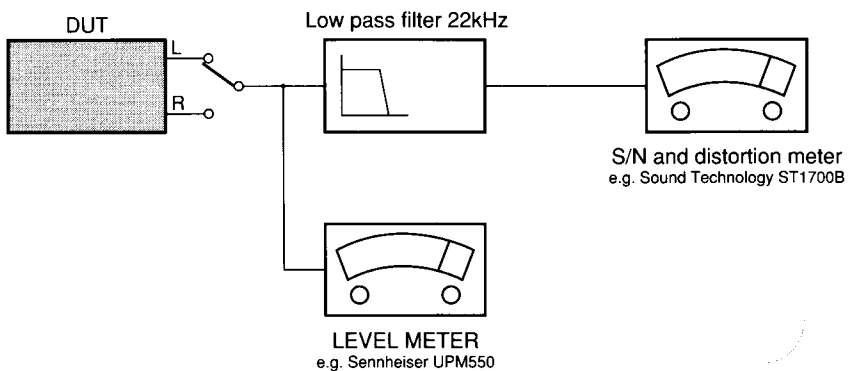

HANDLING CHIP COMPONENTS

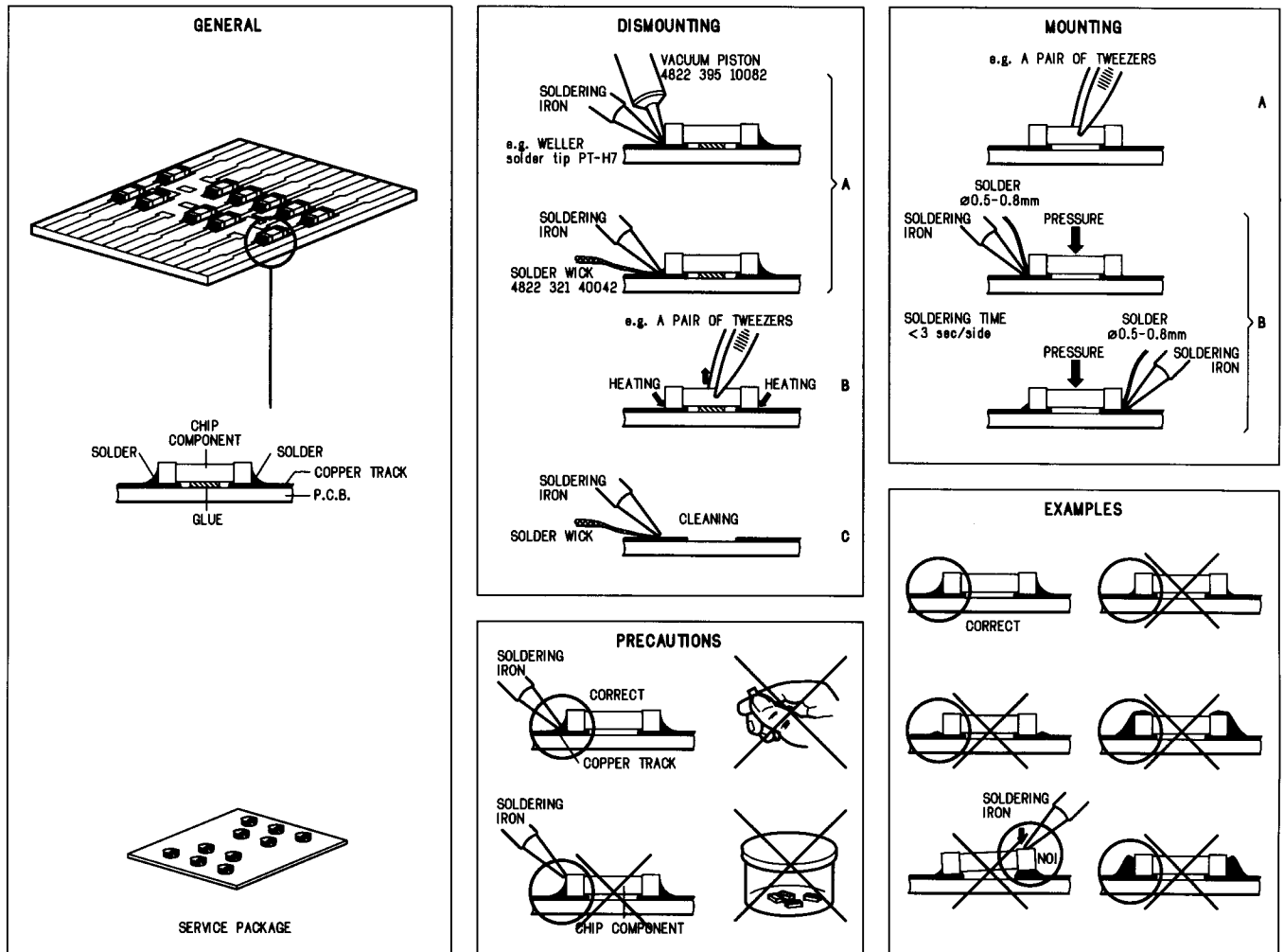
**(GB) WARNING**

All ICs and many other semiconductors are susceptible to electrostatic discharges (ESD). Careless handling during repair can reduce life drastically. When repairing, make sure that you are connected with the same potential as the mass of the set via a wrist wrap with resistance. Keep components and tools at this potential.

(F) ATTENTION

Tous les IC et beaucoup d'autres semi-conducteurs sont sensibles aux décharges statiques (ESD). Leur longévité pourrait être considérablement écourtée par le fait qu'aucune précaution n'est prise à leur manipulation. Lors de réparations, s'assurer de bien être relié au même potentiel que la masse de l'appareil et enfilez le bracelet serti d'une résistance de sécurité. Veiller à ce que les composants ainsi que les outils que l'on utilise soient également à ce potentiel.

(GB)

Safety regulations require that the set be restored to its original condition and that parts which are identical with those specified be used.

(D)

Bei jeder Reparatur sind die geltenden Sicherheitsvorschriften zu beachten. Der Originalzustand des Gerätes darf nicht verändert werden. Für Reparaturen sind Originalersatzteile zu verwenden.

(S) Varning !

Ösynlig laserstrålning när apparaten är öppnad och spårren är urkopplad. Betrakta ej strålen.

(F)

"Pour votre sécurité, ces documents doivent être utilisés par des spécialistes agréés, seuls habilités à réparer votre appareil en panne".

ESD**(D) WARNUNG**

Alle ICs und viele andere Halbleiter sind empfindlich gegenüber elektrostatischen Entladungen (ESD). Unvorsichtige Behandlung im Reparaturfall kann die Lebensdauer drastisch reduzieren. Sorgen Sie dafür, daß sie im Reparaturfall über ein Pulsarmband mit Widerstand mit dem Massepotential des Gerätes verbunden sind. Halten Sie Bauteile und Hilfsmittel ebenfalls auf diesem Potential.

(I)

Le norme di sicurezza estigono che l'apparecchio venga rimesso nelle condizioni originali e che siano utilizzati i pezzi di ricambio identici a quelli specificati.

(F)

Les normes de sécurité exigent que l'appareil soit remis à l'état d'origine et que soient utilisées les pièces de rechange identiques à celles spécifiées.

(DK) Advarsel !

Usynlig laserstrålning ved åbning når sikkerhedsafbrydere er ude af funktion. Undgå udsættelse for strålning.

(NL) WAARSCHUWING

Alle IC's en vele andere halfgeleiders zijn gevoelig voor electrostatische ontladingen (ESD). Onzorgvuldig behandelen tijdens reparatie kan de levensduur drastisch doen verminderen. Zorg ervoor dat u tijdens reparatie via een polsband met weerstand verbonden bent met hetzelfde potentiaal als de massa van het apparaat. Houd componenten en hulpmiddelen ook op ditzelfde potentiaal.

(I) AVVERTIMENTO

Tutti IC e parecchi semi-conduttori sono sensibili alle scariche statiche (ESD). La loro longevità potrebbe essere fortemente ridotta in caso di non osservazione della più grande cautela alla loro manipolazione. Durante le riparazioni occorre quindi essere collegato allo stesso potenziale che quello della massa dell'apparecchio tramite un braccialeto a resistenza. Assicurarsi che i componenti e anche gli utensili con quali si lavora siano anche a questo potenziale.

(NL)

Veiligheidsbepalingen vereisen, dat het apparaat in zijn oorspronkelijke toestand wordt teruggebracht en dat onderdelen, identiek aan de gespecificeerde, worden toegepast.

(SF) Varoitus !

Avatussa laitteessa ja suojalukituksen ohitettaessa olet alttiina näkymättömälle laserisäteilylle. Älä katso säteeseen !

Connections & Controls

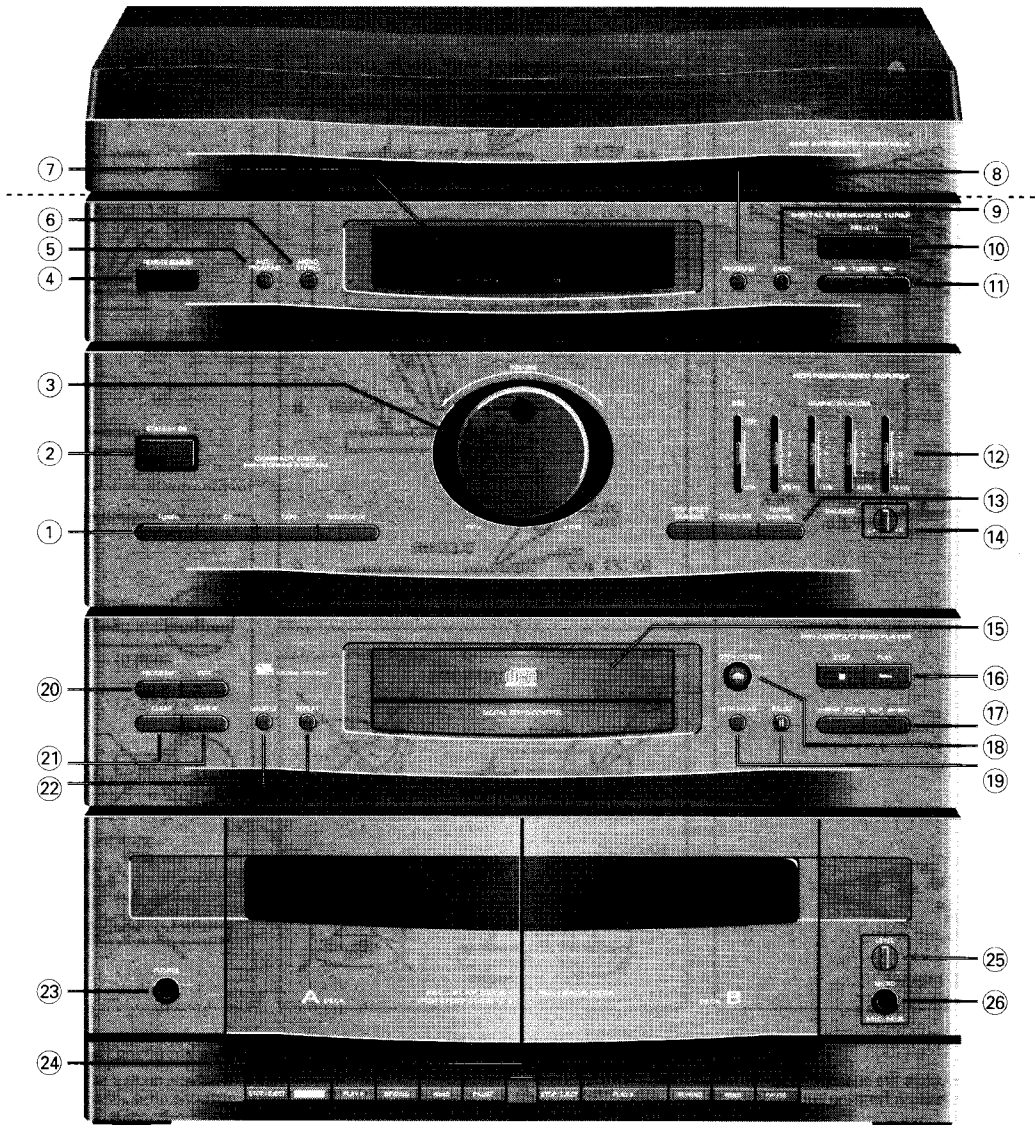

- | | | | |
|--|-----------------|---|-----------------|
| 1 Source selector
Tuner.....1440
CD.....1438
Tape.....1444
Phono/Aux1437 | see page 25, 26 | 13 High Speed Dubbing..1433
Dolby NR.....1420
Ferro/Chrome.....1423 | see page 29, 30 |
| 2 Stand by.....1439 | see page 29, 30 | 14 Balance3479 | see page 25, 26 |
| 3 Volume.....3480 | see page 25, 26 | 15 CD Tray | |
| 4 Remote sensor.....7422 | see page 25, 26 | 16 Play (CD)1457 | see page 29, 30 |
| 5 Auto Program.....1436 | see page 29, 30 | Stop (CD).....1424 | |
| 6 Mono/Stereo1448 | see page 29, 30 | 17 Track skip (CD) | |
| 7 Display1415 | see page 29, 30 | ◀◀.....1454 | see page 29, 30 |
| 8 Program (Tuner)1435 | see page 29, 30 | ▶▶.....1455 | see page 29, 30 |
| 9 Band.....1434 | see page 29, 30 | 18 Open/Close (CD)1456 | see page 29, 30 |
| 10 Presets | see page 29, 30 | 19 Introsan (CD).....1452 | see page 29, 30 |
| Up1425 | | Pause (CD)1451 | see page 29, 30 |
| Down.....1426 | | 20 Program (CD).....1459 | see page 29, 30 |
| 11 Tuning | see page 29, 30 | Edit (CD)1445 | see page 29, 30 |
| Up1421 | | 21 Review1458 | |
| Down.....1422 | | Clear1462 | |
| 12 Graphic Equalizer | see page 25, 26 | 22 Shuffle.....1463 | |
| 100Hz/DBB3485 | | Repeat1453 | |
| 300Hz.....3484 | | 23 Headphone socket.....1410 | see page 25, 26 |
| 1kHz.....3483 | | 24 Tape transport keys ...mechanical | |
| 4kHz.....3482 | | | |
| 10kHz.....3481 | | | |

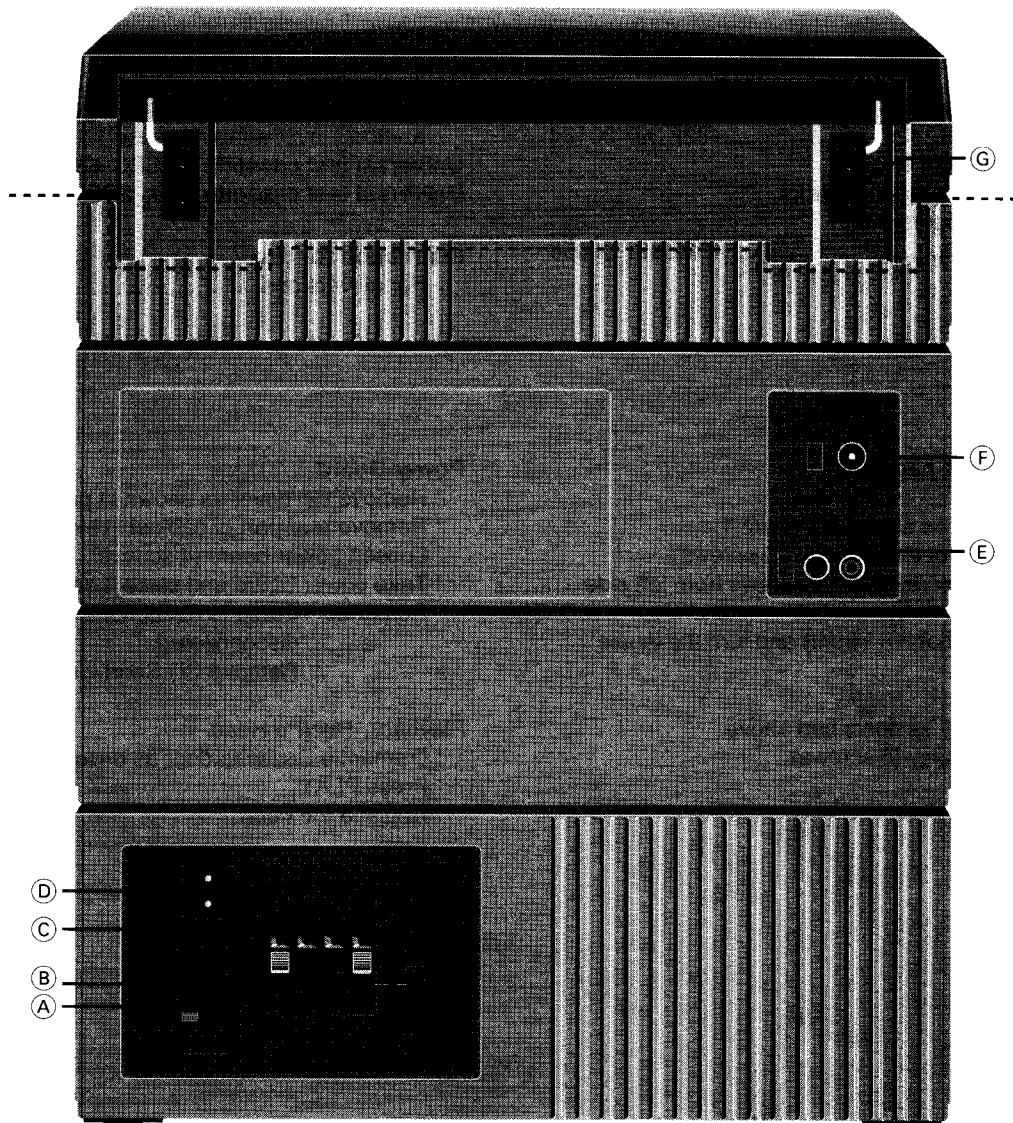

- | | | |
|-----------------------------|------|-----------------|
| A Voltage selector | 1260 | see page 42 |
| B Phono supply | 1305 | |
| for all versions except /22 | | see page 37, 38 |
| for /22 only | | see page 41, 42 |
| C Speaker terminal | 1304 | |
| for all versions except /22 | | see page 37, 38 |
| for /22 only | | see page 41, 42 |
| D Mains socket | 1255 | see page 42 |
| E Aux / Phono sockets .. | 1408 | see page 25, 26 |
| F FM aerial socket | 1101 | |
| for ECO 4 Tuner | | see page 44 |
| FM aerial socket | 1110 | |
| for Tuner 92 | | see page 50 |

Not on all versions

VOLTAGE SELECTOR

SERVICE HINTS

Service Tools

TORX screwdriver set SBC 163.....	4822 295 50145
Audio signal disc SBC 429	4822 397 30184
Test disc 5 (disc without errors)	
Test disc 5A (disc with dropout errors, black spots and fingerprints)	
SBC 426/426A.....	4822 397 30096

Burn in test disc (65 min. 1kHz signal at -30dB level without "pause").....	4822 397 30155
Universal test cassette Fe SBC 420	4822 397 30071
Universal test cassette CrO₂ SBC 419.....	4822 397 30069

Instruction for use	
For all versions	4822 736 22107

Dismantling of:

CD Short Loader: see page 56ff

Front assy

- * Remove top cover as shown in picture 1.
- * Remove right side of the cabinet (10 screws)
- * Remove 3 bottom screws and 3 screws from left side wall on front side.
- * Remove 2 snaps (bottom - front) and turn the whole front assy aside.

Tape Transports

- * Separate front assy as described above.
- * Loosen Recorder assy (6 screws)

Power Board

- * Remove top cover as shown in picture 1.
 - * Remove rear part of cabinet (19 screws)
 - * Loosen power board (4 screws).
 - * Take power board and place it behind the set.
- Remarks: Cable to headphone socket has to be disconnected.
Remove CD Short loader if necessary.

Playback, -Rec/Pb Head

- * Dismantle Cassette door as described in picture 3 and 4.
- * Press PLAY.
- * Replace the head.

Dismantling Hints

Dismantling of Top Cover

Remove 3x screws.

1. Press torx screw driver into holes (see picture 1) to release hidden snaps.
2. Lift top cover.

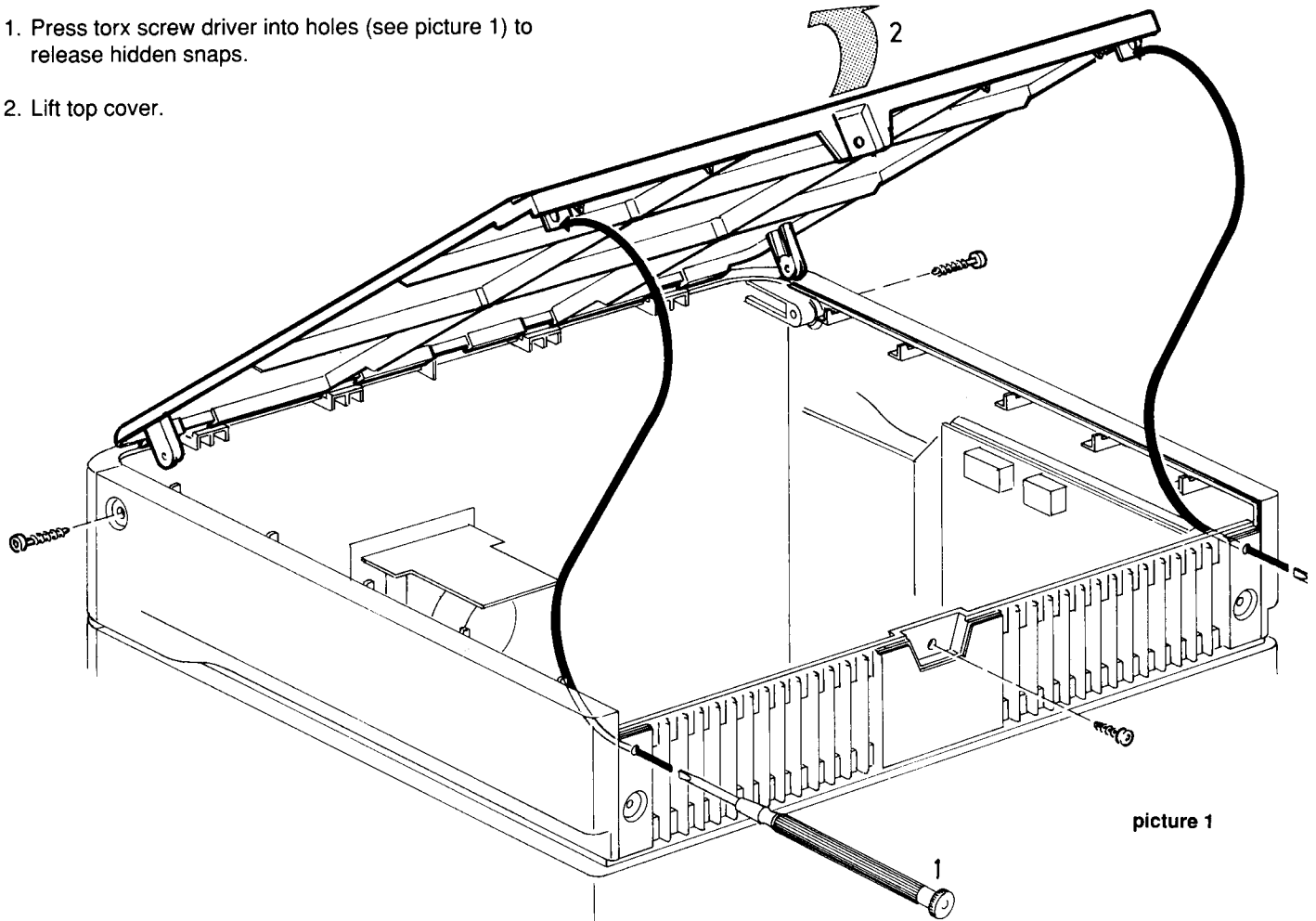

Dismantling Window of Cassette Door

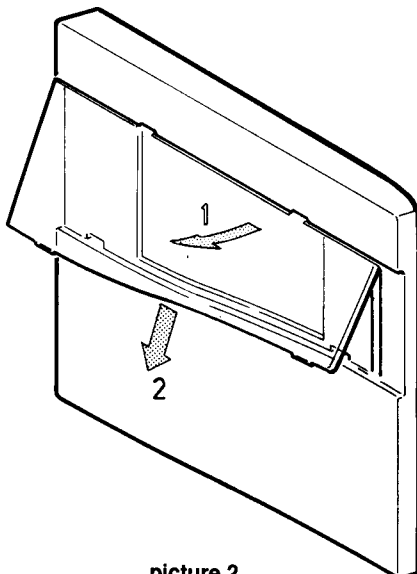

- 1) Press the window outside as shown in picture 2.
You don't need any tool.

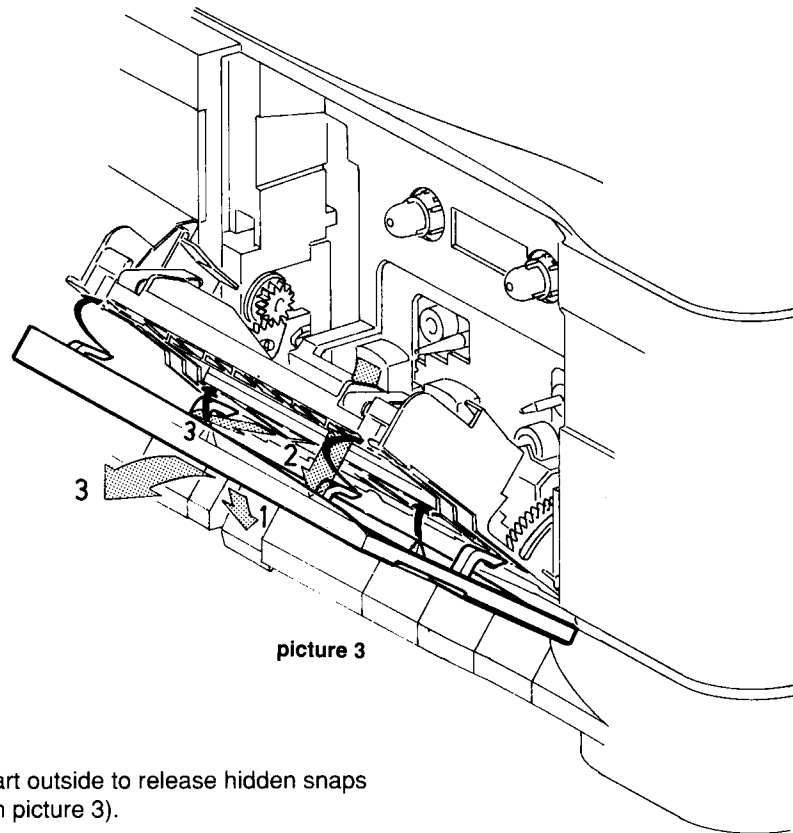
Dismantling Cassette Door Ornamental Part

- 1) Open cassette door.
- 2) Press ornamental part outside to release hidden snaps (see black arrows on picture 3).
- 3) Pull ornamental part upwards.

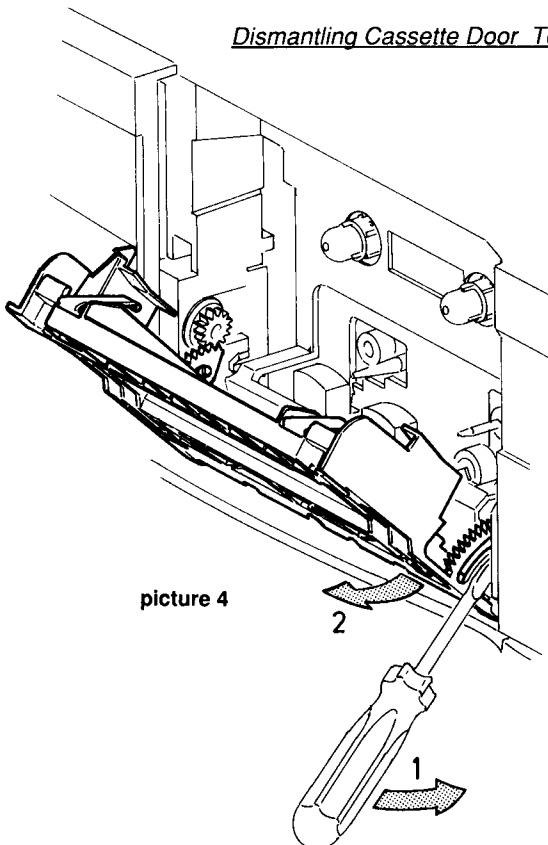
Dismantling Cassette Door Technical Part

Remove ornamental part first.

- 1) Bend tooth segment with a screw driver to release snap as shown in picture 4.
- 2) Pull cassette door outside.

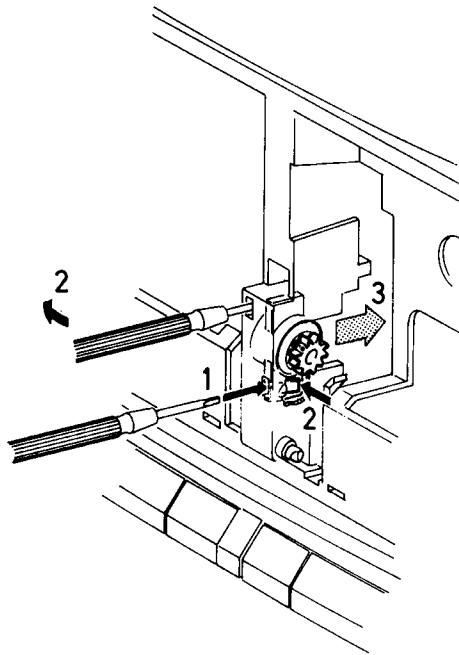
Dismantling of Damper

picture 5

Remove Tape Transports and bracket (506) first.

1+2) Release two snaps as shown in picture 5.

3) Pull damper outside.

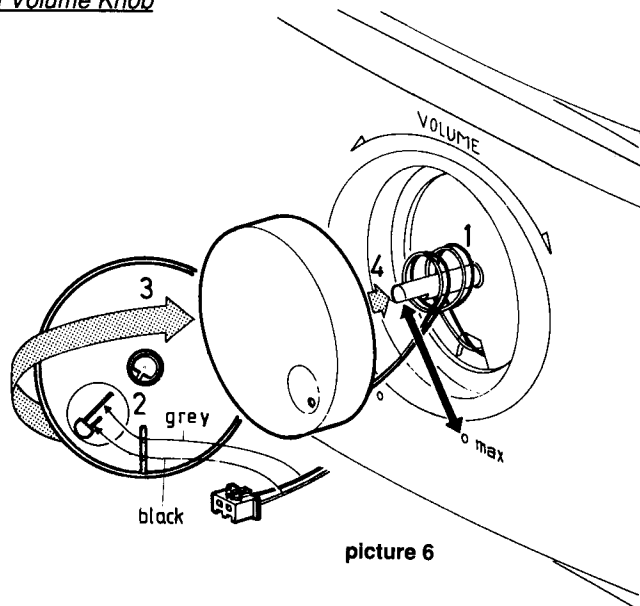
Mounting of Volume Knob

picture 6

- 1) Turn Volume pot to max. (clockwise)
- 2) Pay attention to the polarity of the LED.
- 3) Turn the cable two times clockwise onto the axle.
- 4) Insert the knob.

SERVICE TEST PROGRAM

The service test programm can be left:

- at each step: by switching power off (disconnect mains)

- from service main menu:

by pressing the Standby button twice the set is switched to normal working mode except: * in TUNER mode still the service preset frequencies are available.

* in CD mode the error codes will be displayed.

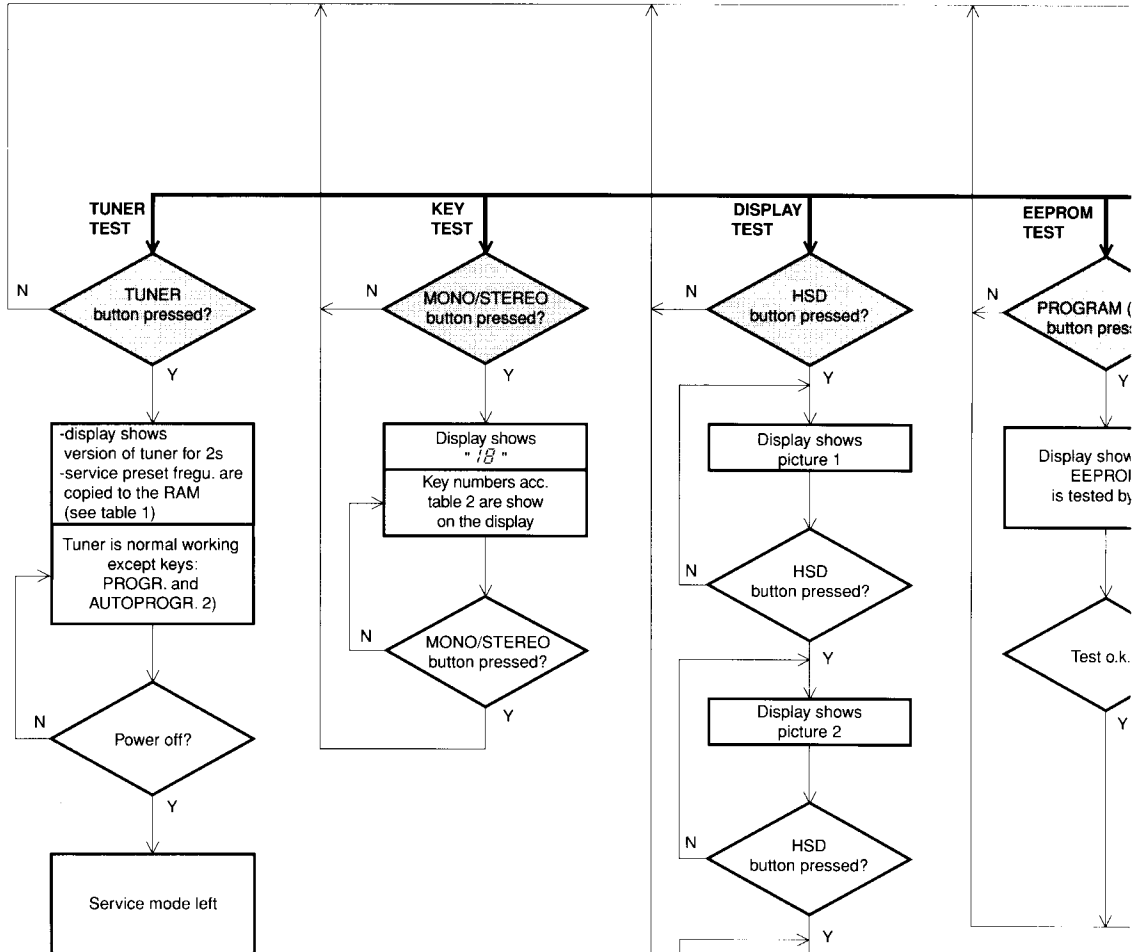

2) Preset frequencies of table 1 can be used as in normal tuner mode. If field strength is high enough "PROGRAM" flag will light. Preset frequencies stored by the customer are still stored in the EEPROM and can be recalled by a reset of the μ P (switching power off by disconnecting mains cord)



Picture 1

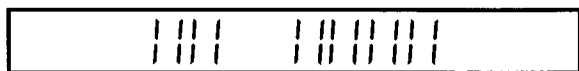

Picture 2



Picture 3

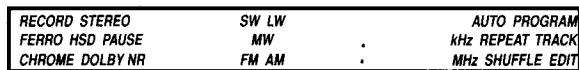

Picture 4

To start service test program hold **PROGR. & PRESET UP** buttons depressed while plugging in the mains cord

Display shows set name and number of ROM version "54 xx S" 1) (Main menu)

1) 54 stands for AS 440 or AS 540
 64 stands for AS 640
 xx version number of software
 S stands for Service test program
 divided quartz frequency of front μ P (61 Hz) can be measured on pin 34 of the display

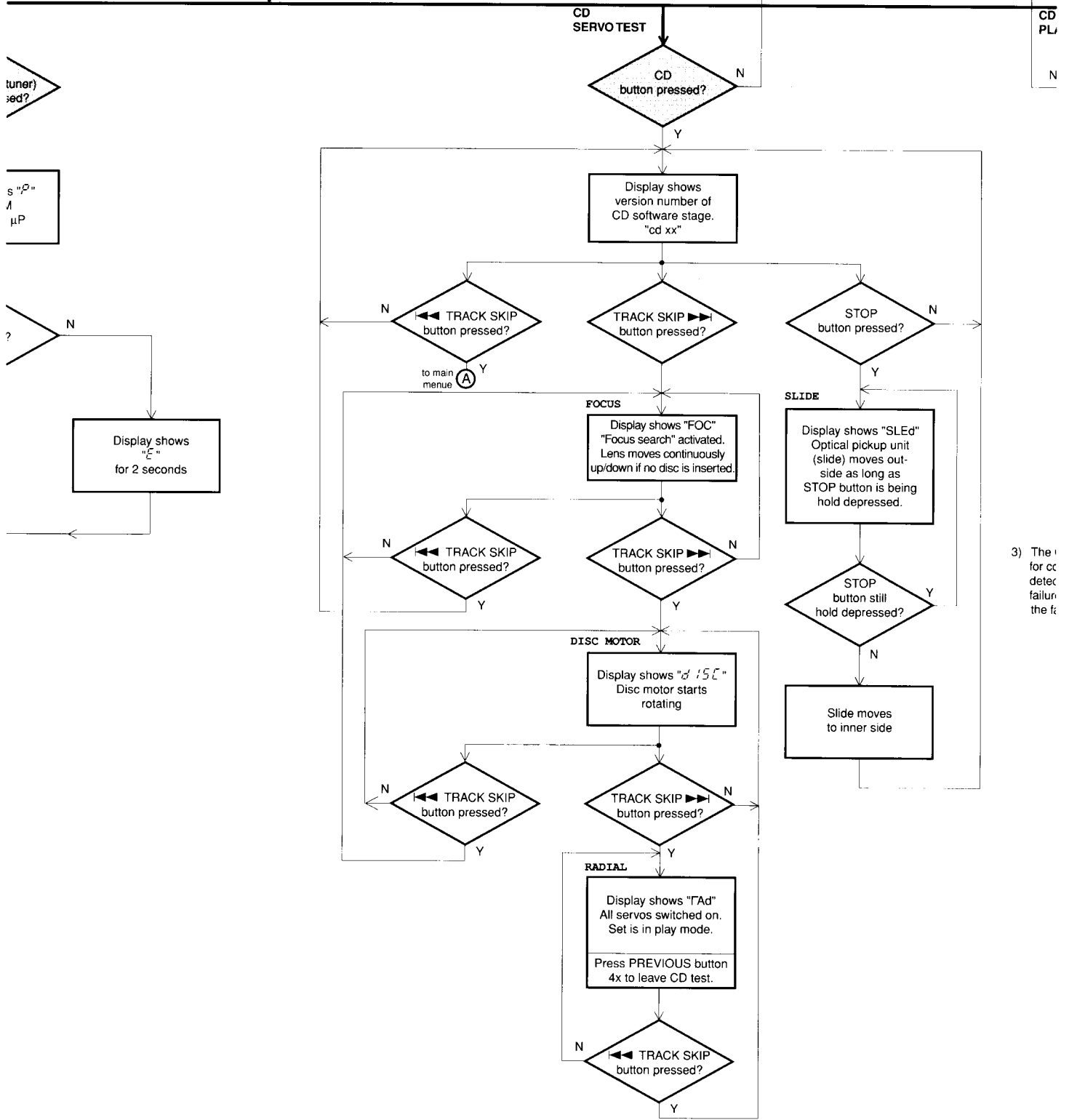

3) The ... for cc defect failure the f

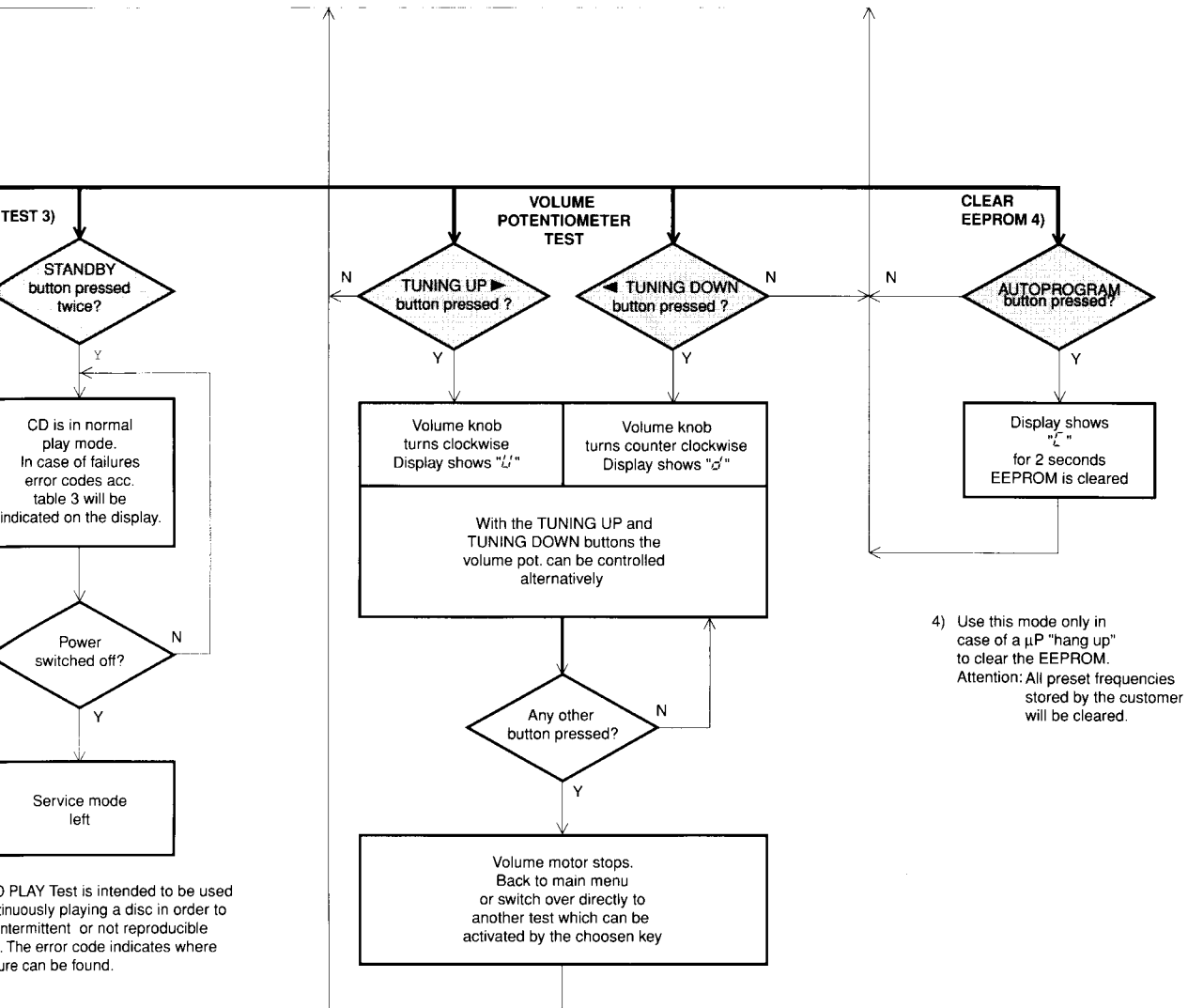

4) Use this mode only in case of a μP "hang up" to clear the EEPROM. Attention: All preset frequencies stored by the customer will be cleared.

PLAY Test is intended to be used continuously playing a disc in order to intermittent or not reproducible. The error code indicates where failure can be found.

PRESET	VERSION						UNIT
	EUR	EAS	USA	EUS	OSE	OSS	
	Europe 3-band	East Europe 3-band	USA 2-band	Europe 4-band	Oversea 2-band	Oversea 3-band	
1	87,5	65,81	87,5	87,5	87,5	87,5	MHz
2	108	74	108	108	108	108	MHz
3	98	87,5	98	98	98	98	MHz
4	89,7	108	89,7	89,7	89,7	89,7	MHz
5	93	98	93	93	93	93	MHz
6	104,9	89,7	104,9	104,9	104,9	104,9	MHz
7	522	93	530	522	530	530	kHz
8	1611	104,9	1710	1611	1710	1710	kHz
9	540	522	540	540	540	540	kHz
10	549	1611	550	549	550	550	kHz
11	558	540	560	558	560	560	kHz
12	1494	549	1500	1494	1500	1500	kHz
13	153	558	1600	153	1600	1600	kHz
14	279	1494	1000	279	1000	3900	kHz
15	156	153		156		12100	kHz
16	198	279		198		4250	kHz
17	270	156		270		8000	kHz
18	999	198		5900		11900	kHz
19		270		18100		1000	kHz
20		999		6200			kHz
21				17000			kHz
22				12000			kHz
23				999			kHz

table 1

Key activated	Display shows	Key activated	Display shows
Tuning up	01	Autoprogram	17
Tuning down	03	Mono / Stereo	18
Preset up	04	Tuner	19
Preset down	02	Stand by	20
Dolby ¹⁾	05	Tape	21
Band	06	Phono / Aux	22
Program(Tuner)	07	CD	23
Fe/Cr ¹⁾	08	—	—
Introsan	09	Repeat	25
Pause (CD)	10	Shuffle	26
« Track skip	11	Review	27
Track skip »	12	Clear	28
HS dubbing	13	—	—
Open/Close	14	Edit ¹⁾	30
Stop (CD)	15	—	—
Play (CD)	16	Program (CD)	32

table 2

If a key is activated at the remote control  is shown additionally to the key number as long as the key is hold depressed.

1) key not available in all versions.

Error code shown on the display	Description
Er 1002	Focus error
Er 1007	Subcode error, no valid subcode
Er 1008	TOC error, out of lead-in area while reading TOC
Er 1009	CD4 + decoder error
Er 1010	Radial error
Er 1012	Fatal sledge error
Er 1013	Turntable motor error
Er 1030	Too many grooves to jump
Er 1031	Search error
Er 1032	Search binary error
Er 1033	Search index error
Er 1034	Search time error
Er 1037	Selector error
Er 1050	Edit calculation error
Er 1051	Edit track count error
Er 1052	Edit Optimal error

table 3

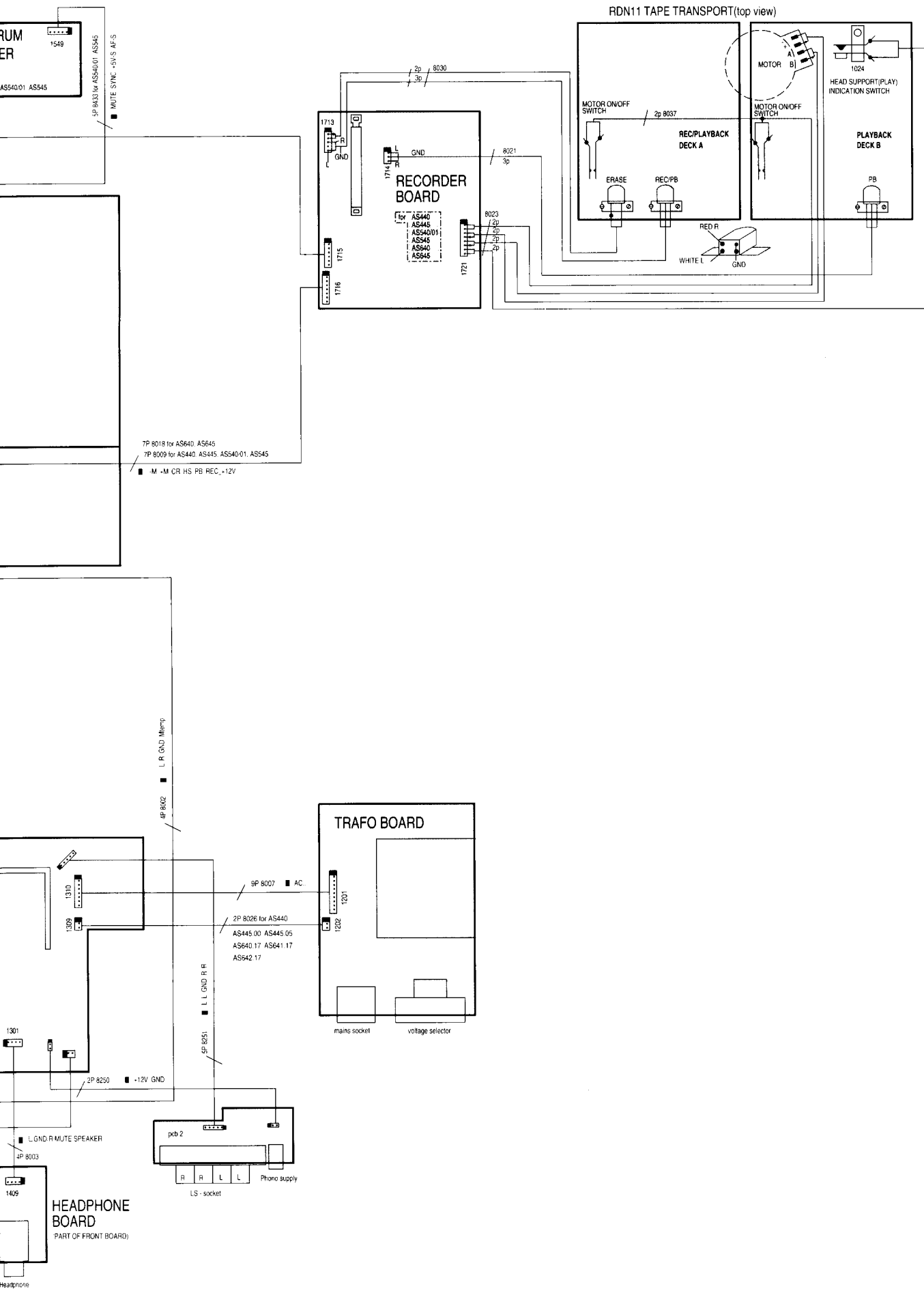

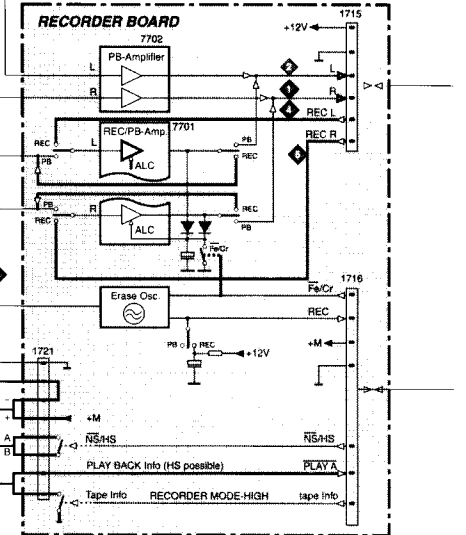
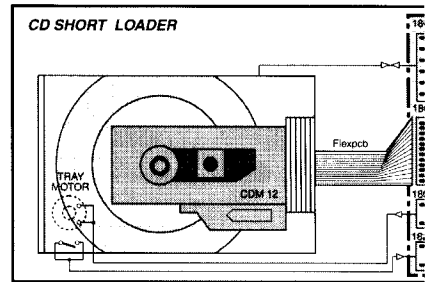
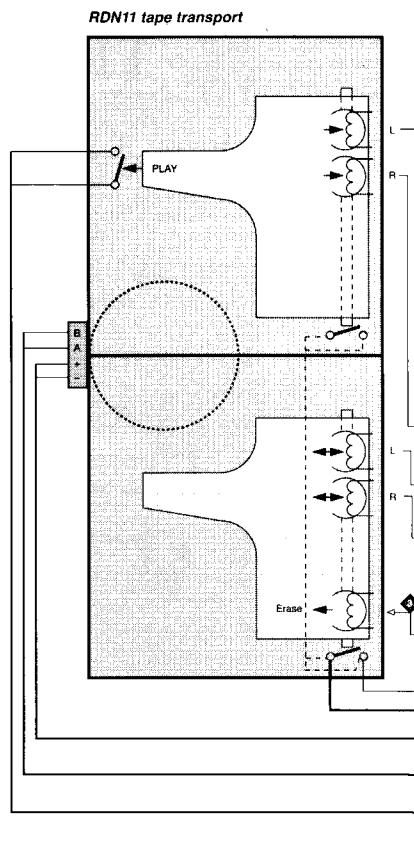
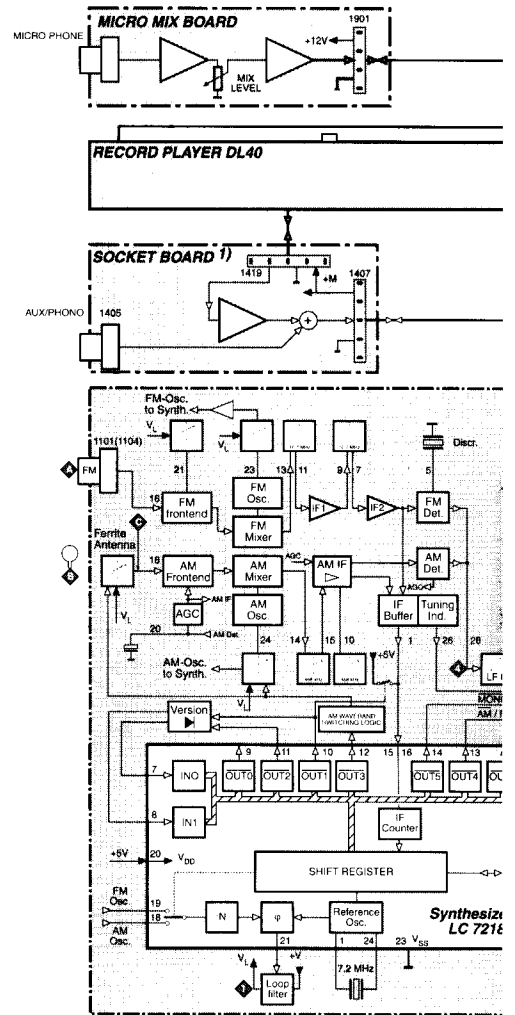

APPARATUS BLOCK DIAGRAM

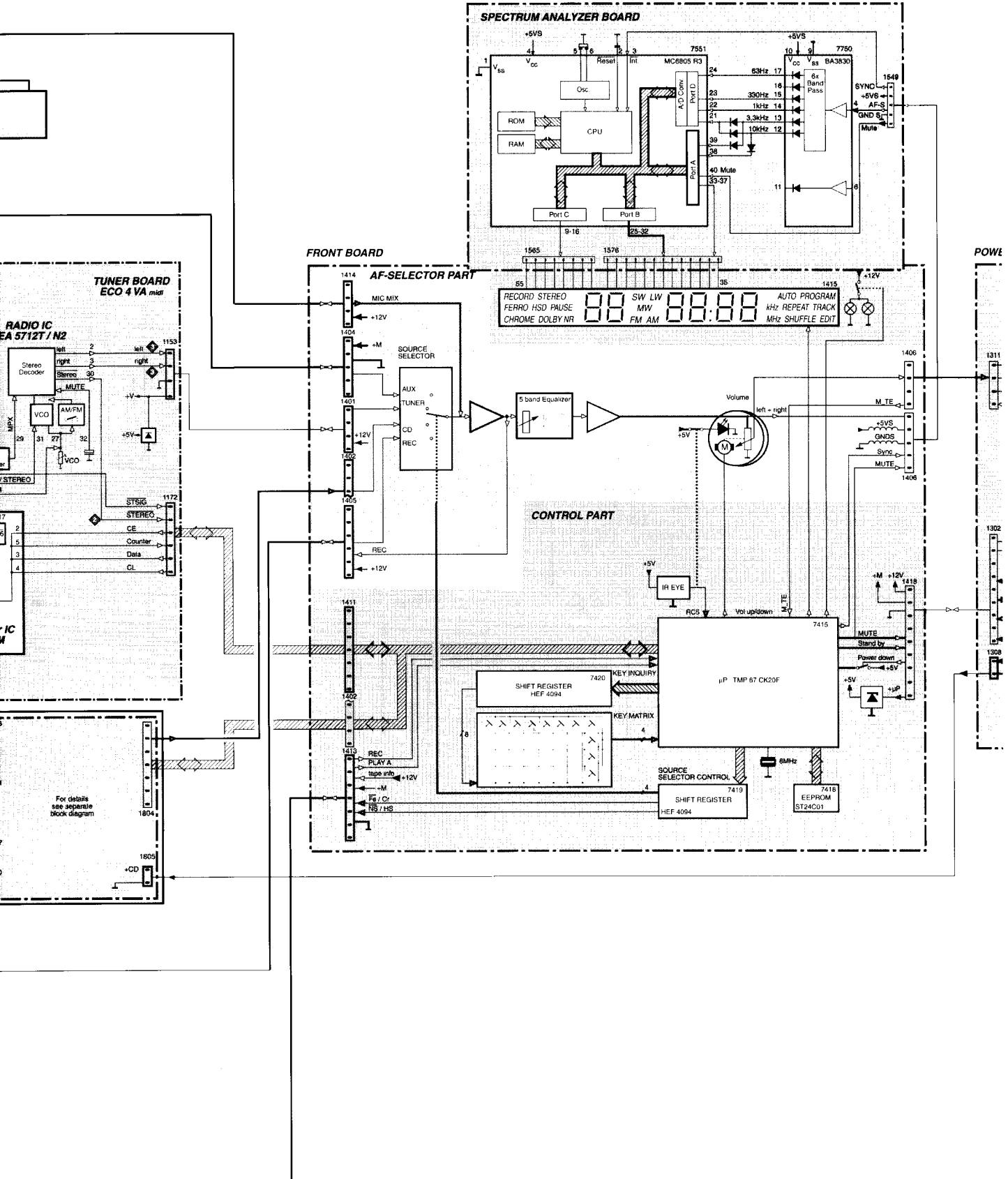

FR BOARD

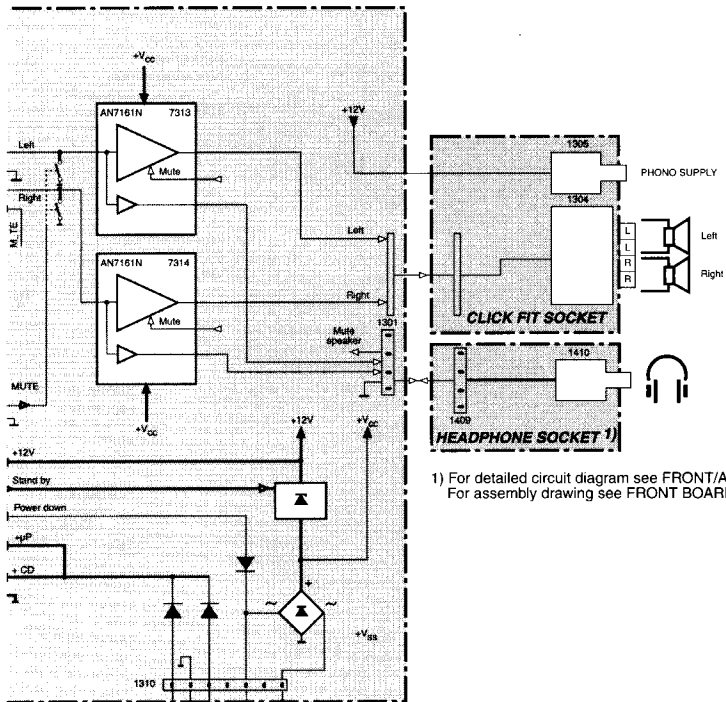

1) For detailed circuit diagram see FRONT/AF part.
For assembly drawing see FRONT BOARD.

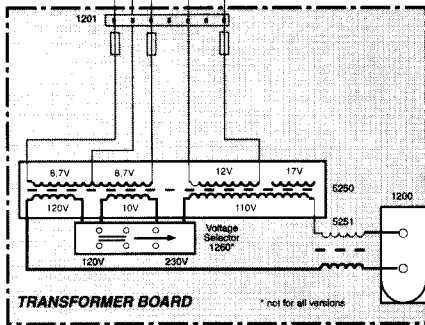

9483	B	10	6450	C	9	3569
9484	E	8	6453	F	7	3570
9485	E	8	7403	C	12	3571
9486	E	6	7406	F	6	3572
9487	E	6	7407	F	2	3573
9488	E	6	7408	F	2	3574
9489	E	8	7409	F	7	3575
9490	E	8	7410	F	7	3576
9491	C	10	7411	F	7	3577
9492	C	10	7412	F	6	3578
9493	B	4	7413	F	8	3579
9494	A	5	7418	C	4	3580
9495	C	10	7419	E	4	3581
9496	A	9	7420	R	11	3582
9497	D	3	7421	D	5	3583
9498	A	5	7422	B	1	3584
9499	C	9	7423	D	9	3585
9500	F	10	7424	D	9	3586
9501	B	7	7425	E	5	3587
9503	F	12	7426	A	11	3589
9504	C	13	7427	D	5	3590
9507	H	10	7428	I	7	3591
9508	C	10	7430	D	9	3592
9509	F	11	7432	D	9	3593
9511	E	3	7433	E	13	3594
9512	E	10	7440	E	9	3595
9513	C	10	7441	R	9	3596
9515	F	4	7445	C	2	3597
9516	C	9	7446	C	2	3598
9518	D	11	7447	I	9	3601
9519	C	13	7448	I	9	3602
9520	D	10	8400	D	7	3603
9521	D	10	8433	H	10	3604
9522	C	10	9401	C	5	3605
9523	C	8	9402	A	6	3606
9524	C	10	9403	B	5	3607
9527	D	6	9404	A	4	3608
9528	C	6	9405	C	8	3609
9530	C	9	9406	B	2	3610
9531	E	6	9408	E	8	3612
9532	D	10	9410	J	6	3613
9533	B	12	9412	F	5	3615
9542	D	1	9413	A	7	3616
9550	D	1	9414	A	8	3617
9551	F	3	9415	A	8	3618
9554	F	3	9416	B	6	3620
9556	E	2	9417	A	4	3621
9557	E	1	9420	E	3	3622
9558	D	1	9421	A	5	3623
9580	F	10	9422	A	5	3624
			9423	B	4	3625
			9424	C	5	3649
			9425	D	9	3650
			9426	E	10	3651
			9427	C	8	3652
			9428	C	9	3653
			9429	G	3	3654
			9430	F	4	3655
			9431	E	9	3660
			9432	C	1	3661
			9433	C	1	3662
			9434	F	2	3663
			9435	B	2	3664
			9436	D	9	3665
			9437	C	2	3666
			9438	C	3	3667
			9439	C	6	3668
			9440	F	3	3670
			9443	G	2	3671
			9444	G	2	3681
			9445	D	2	3682
			9446	G	2	3683
			9447	D	3	3684
			9448	F	5	3685
			9449	C	6	3686
			9450	D	2	3687
			9451	D	4	3688
			9452	F	4	3689
			9453	F	3	3690
			9454	D	3	3691
			9455	G	3	3692
			9456	B	8	3693
			9457	F	11	3699
			9459	C	4	3610
			9460	C	4	3611
			9461	D	4	3612
			9462	D	4	3613
			9463	D	4	3614
			9464	D	4	3615
			9465	J	8	3616
			9466	E	4	3618
			9467	E	4	3619
			9468	D	7	3620
			9469	C	1	3621
			9470	G	13	3622
			9471	H	10	3623
			9472	G	11	3624
			9473	G	11	3625
			9474	G	11	3626
			9475	G	12	3628
			9476	G	11	3629
			9477	H	1	3630
			9478	D	7	3631
			9479	E	8	3632
			9480	H	2	3633
			9481	C	18	3634
			9482	C	12	3635

13 12 11 10 9 8

FRONT BOARD Copperside view

9	3435	F	2	2426	F	3	2002	A	9
9	3436	E	3	2427	E	2	2003	A	9
10	3437	D	2	2428	E	3	2004	A	9
11	3438	D	2	2429	E	3	2005	D	7
9	3439	D	10	2430	E	13	1400	E	5
9	3440	D	10	2431	E	12	1401	A	1
9	3441	C	13	2432	E	13	1402	C	1
11	3442	D	13	2433	D	12	1403	C	1
9	3443	D	13	2434	D	13	1404	B	1
9	3444	D	13	2435	E	12	1405	D	1
10	3445	D	12	2436	E	12	1406	E	8
10	3446	D	13	2437	D	12	1407	H	9
10	3447	D	12	2438	D	12	1408	I	8
9	3448	D	12	2439	E	11	1409	I	5
10	3449	D	11	2440	E	11	1410	I	5
10	3450	D	11	2441	D	11	1411	A	4
4	3451	D	11	2442	D	11	1412	D	9
5	3452	D	11	2443	E	10	1413	F	9
5	3453	D	11	2444	E	11	1414	F	6
11	3454	C	12	2445	D	11	1415	A	5
4	3455	E	10	2446	D	10	1416	B	6
11	3456	F	11	2447	C	4	1417	H	7
4	3457	E	11	2448	C	4	1418	F	5
11	3458	F	11	2449	C	13	1419	H	10
10	3459	E	12	2450	C	12	1420	F	11
9	3460	E	12	2451	C	11	1421	B	13
9	3461	E	12	2452	C	12	1422	B	12
5	3462	E	12	2453	D	13	1423	F	12
2	3463	C	11	2454	B	13	1424	I	12
2	3464	D	12	2455	C	11	1425	A	13
3	3465	C	12	2456	C	12	1426	A	12
2	3466	C	12	2459	A	11	1427	I	10
2	3469	C	12	2460	D	3	1428	I	13
1	3470	C	12	2461	D	3	1429	I	10
2	3471	E	13	2462	D	4	1430	I	11
2	3472	E	13	2463	D	3	1431	I	12
2	3473	C	13	2464	E	3	1432	I	13
2	3474	D	13	2465	F	8	1433	F	10
10	3475	F	2	2466	C	13	2436	B	11
5	3476	E	3	2468	C	1	1435	B	11
2	3477	F	8	2469	H	9	1436	B	3
2	3478	F	7	2470	T	9	1437	F	4
2	3479	F	13	2471	H	8	1438	F	2
6	3480	D	7	2472	I	8	1439	E	1
6	3481	D	13	2473	I	9	1440	F	1
6	3482	D	12	2475	A	2	1441	I	1
1	3483	D	12	2476	F	10	1442	I	3
1	3484	D	11	2477	I	10	1443	F	3
2	3485	D	11	2480	I	8	1444	F	3
10	3486	E	3	2481	E	8	1445	I	2
10	3487	E	4	2482	B	2	1446	E	1
9	3488	E	3	2483	E	3	1447	I	2
9	3489	E	2	2484	F	3	1448	B	3
10	3490	F	1	2485	A	9	1449	E	8
9	3491	F	8	2502	E	5	1450	J	5
8	3492	F	7	2503	D	3	1451	J	6
9	3493	E	7	2504	B	6	1452	J	13
9	3494	E	7	2505	A	11	1453	J	12
9	3495	E	8	2506	B	5	1454	J	4
9	3496	E	8	2507	B	12	1455	J	3
10	3497	E	6	2508	A	3	1456	J	1
10	3498	E	6	2509	A	3	1457	J	2
7	3499	E	8	2510	A	4	1458	J	10
7	3500	A	4	2511	D	5	1459	J	10
7	3501	C	9	2512	E	5	1460	J	8
9	3502	C	9	2513	E	5	1461	J	9
5	3503	A	12	2514	C	4	1462	J	11
8	3504	A	12	2551	A	11	1463	J	10
8	3505	A	12	2552	I	9	1464	A	12
5	3506	C	5	2553	I	9	1465	A	4
5	3507	B	4	2554	I	5	1466	F	3
10	3508	B	4	2555	I	5	1467	J	7
10	3509	D	10	2556	D	13	1468	F	10
2	3516	A	3	2557	D	13	1469	J	7
2	3517	A	3	2558	C	12	1470	H	7
3	3526	D	5	3401	A	1	1471	A	5
3	3528	F	2	3402	A	1	1472	H	10
3	3529	A	1	3403	A	1	1473	I	2
4	3530	A	3	3404	A	1	1474	I	1
7	3531	A	3	3435	C	1	1475	I	1
2	3532	A	3	3436	C	1	1476	F	6
3	3533	A	3	3437	C	1	1477	F	6
3	3534	A	3	3438	C	1	2401	A	2
3	3535	A	3	3439	D	2	2402	A	2
4	3536	A	2	3440	D	2	2403	D	3
2	3537	A	4	3441	D	2	2404	B	2
3	3538	A	4	3442	D	2	2405	D	4
3	3539	A	4	3443	B	1	2406	B	2
3	3540	A	6	3444	H	1	2407	D	2
4	3541	H	7	3445	I	9	2408	B	2
10	3542	H	7	3446	I	8	2409	C	2
10	3543	H	7	3447	D	3	2410	B	3
10	3550	B	5	3448	C	3	2411	C	2
10	3551	F	4	3449	D	4	2412	A	2
11	3553	A	11	3403	D	2	2413	C	4
11	3554	A	11	3411	D	2	2414	B	2
11	3555	A	12	3412	D	3	2415	C	3
11	3556	A	13	3413	D	3	2416	B	3
10	3557	A	13	3414	D	3	2417	C	4
9	3558	B	11	3425	D	1	2418	B	3
7	3559	B	11	3426	E	1	2419	F	3
7	3560	B	11	3427	F	2	2420	F	2
6	3562	D	5	3428	F	2	2421	B	2
10	3563	D	5	3430	F	2	2422	B	2
10	3564	A	11	3432	F	3	2423	B	2
10	3565	A	11	3433	F	3	2424	B	4
2	3568	B	9	3434	F	2	2425	F	2

A
B
C
D
E
F
G
H
I
J

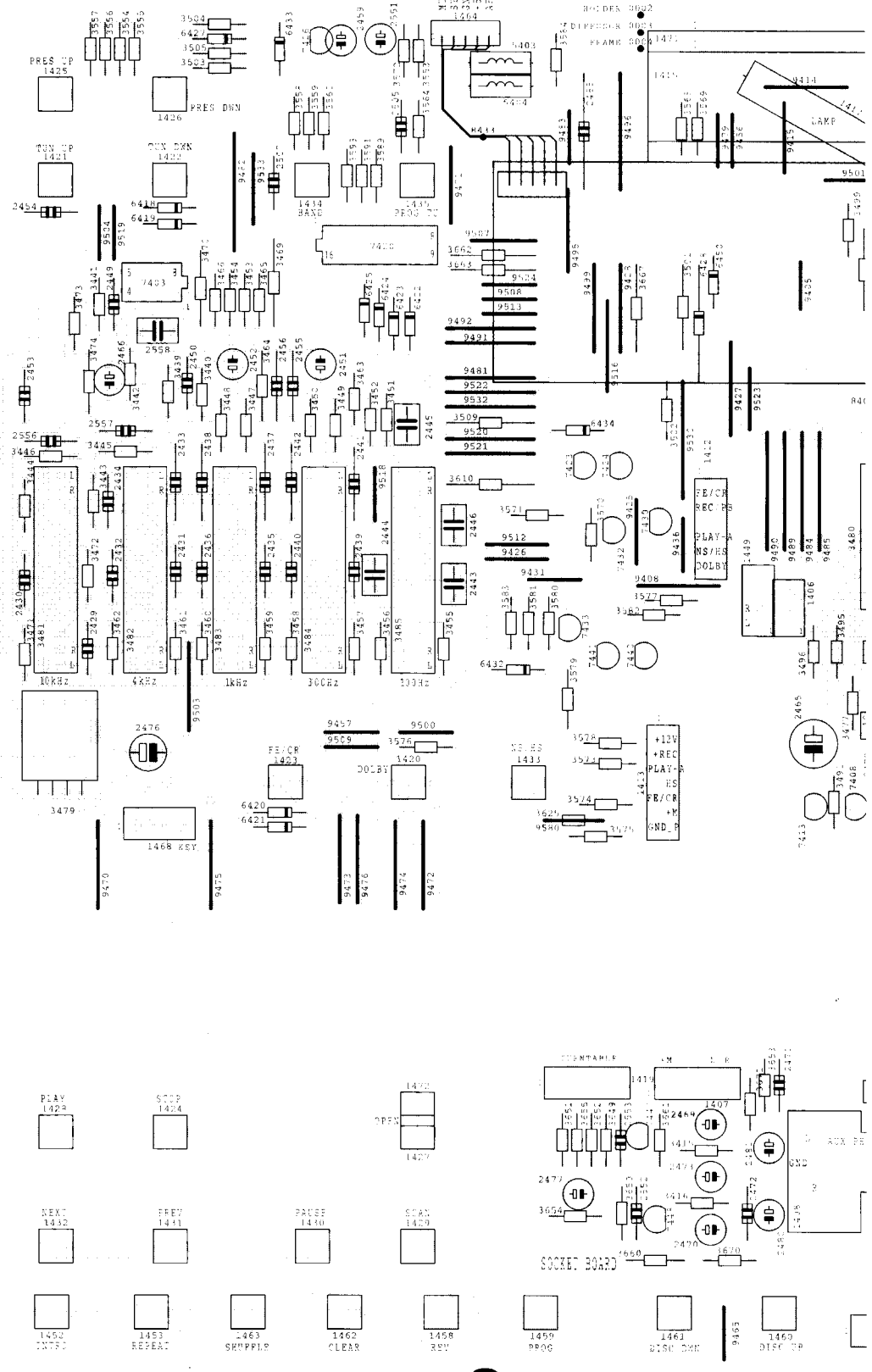

13 12 11 10 9 8

This assembly drawing shows a summary of all possible versions!
For components used in a specific version see schematic diagram respectively partslist

7 6 5 4 3 2 1

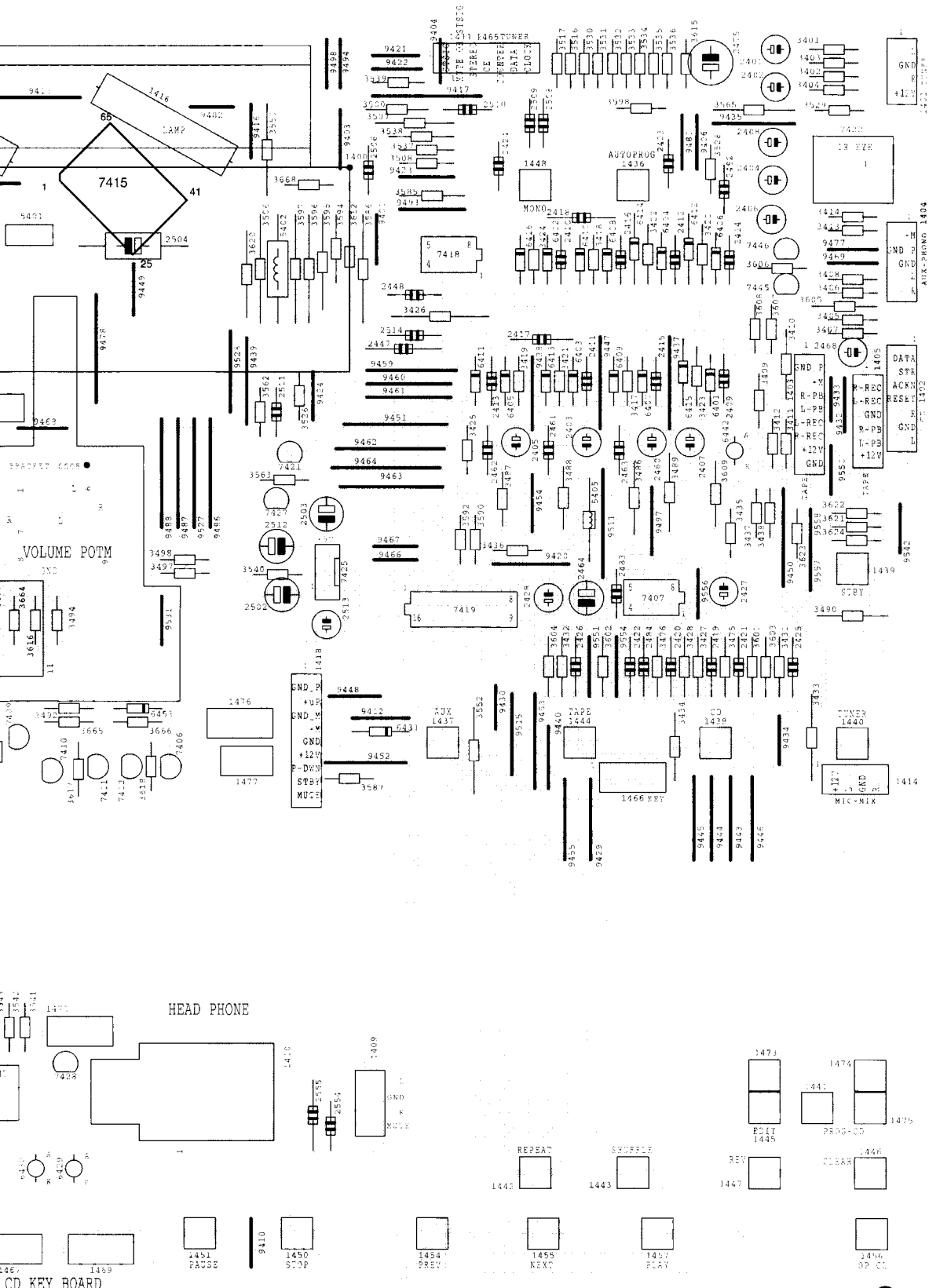

A
B
C
D
E
F
G
H
I
J

7 6 5 4 3 2 1

D19	3478 J17	3483 C14	3489 K 8	3498 J21	3609 I11	3652 L 4	3665 K19	6405 F 6	6414 H 7	7407 D11	7447 L 4	T008 D 2	T019 I 2	T028 B 8	T038 G21
G19	3479 E20	3483 G14	3490 B12	3501 D10	3610 B19	3653 L 5	3666 J21	6406 F 8	6416 H 6	7406 J18	7448 K 4	T009 E 2	T020 L 2	T029 C10	T039 J19
E19	3480 C20	3484 D14	3491 J17	3602 F10	3615 B 8	3654 L 3	3670 J 4	6407 G 6	6418 H 8	7408 J18	T001 B 2	T010 E 2	T021 L 2	T030 E10	T040 J19
H19	3480 G20	3484 G14	3492 I18	3603 E10	3616 I19	3655 L 3	3671 K 3	6408 G 8	6442 I11	7410 J18	T002 B 2	T011 E 2	T022 K 2	T031 J16	T041 K15
E17	3480 J19	3485 D15	3493 I18	3604 G10	3617 I20	3660 K 3	3675 J 6	6409 H 5	6453 H20	7411 J20	T003 B 3	T014 G 3	T023 K 2	T032 J16	T042 K20
C10	3481 B14	3485 F15	3494 I19	3606A J12	3618 J21	3661 M 3	6401 C 6	6410 H 7	7403 G18	7412 J20	T004 B 2	T015 G 3	T024 L 2	T033 J16	T043 H 1
E10	3481 H4	3486 K 7	3495 I19	3606A J12	3649 L 4	3662 F13	6402 D 8	6411 H 5	7403 D18	7413 J20	T005 C 2	T016 G 3	T025 L 2	T034 K16	T044 J 9
E10	3482 B14	3487 K 7	3496 I20	3607 H13	3650 L 4	3663 E13	6403 D 6	6412 H 7	7406 I21	7445 H12	T006 D 2	T017 G 3	T026 M 2	T036 D21	T046 J10
K19	3482 H14	3488 K 7	3497 I21	3608 H11	3651 L 4	3664 I18	6404 E 8	6413 H 6	7407 E11	7446 H11	T007 D 2	T018 H 2	T027 M 2	T037 D21	

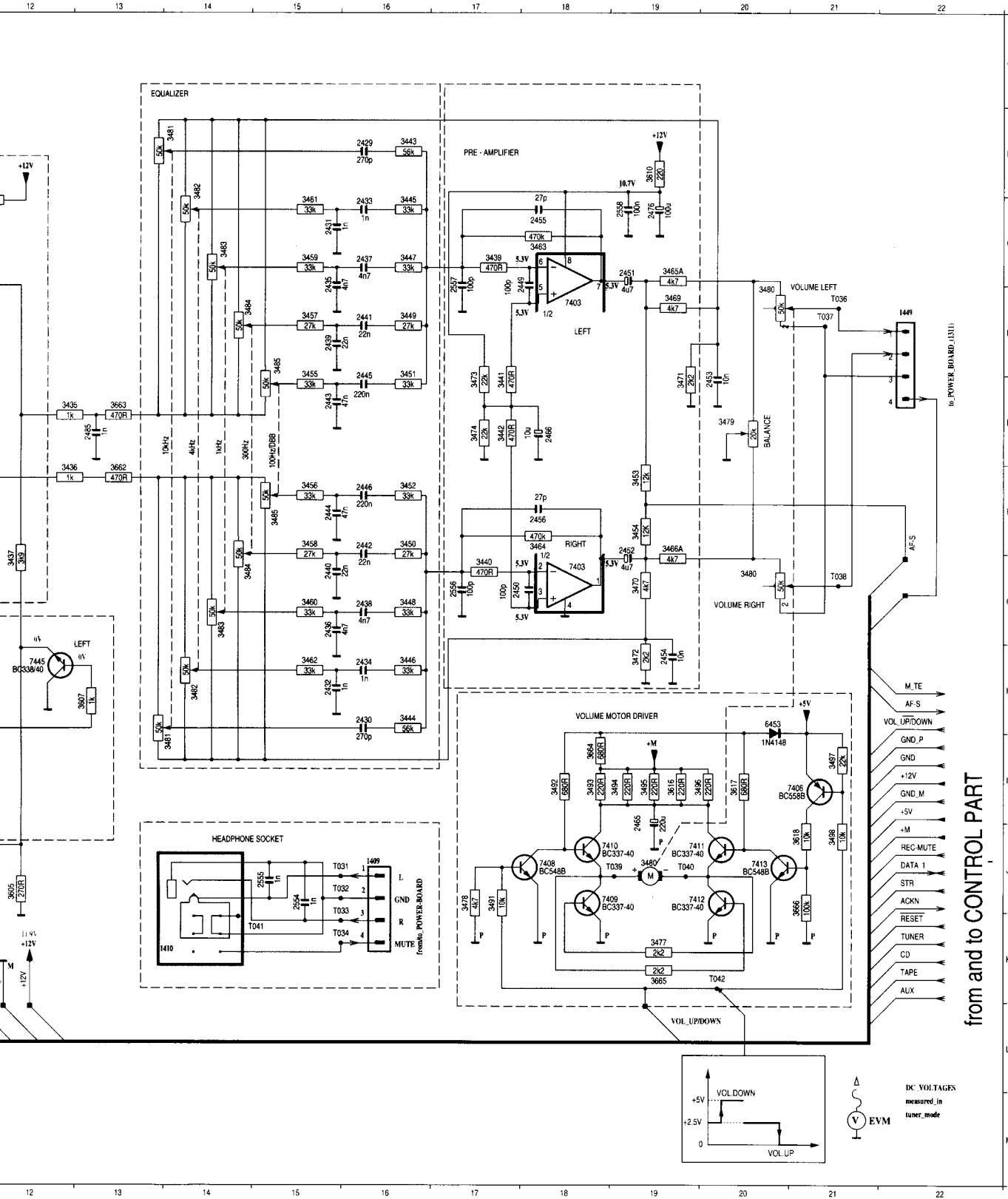

from and to CONTROL PART

1 2 3 4 5 6 7 8

FRONT BOARD Component side view

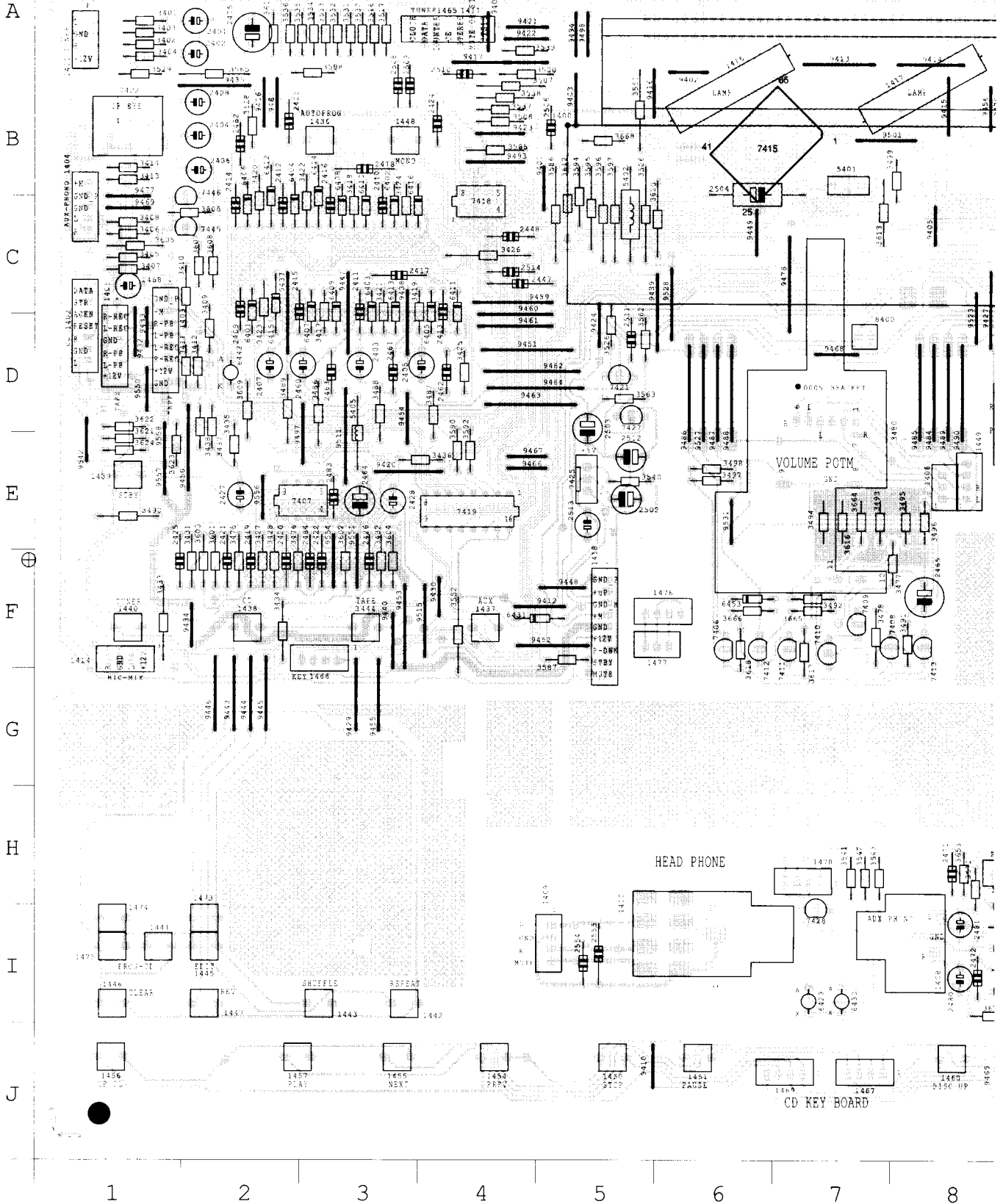



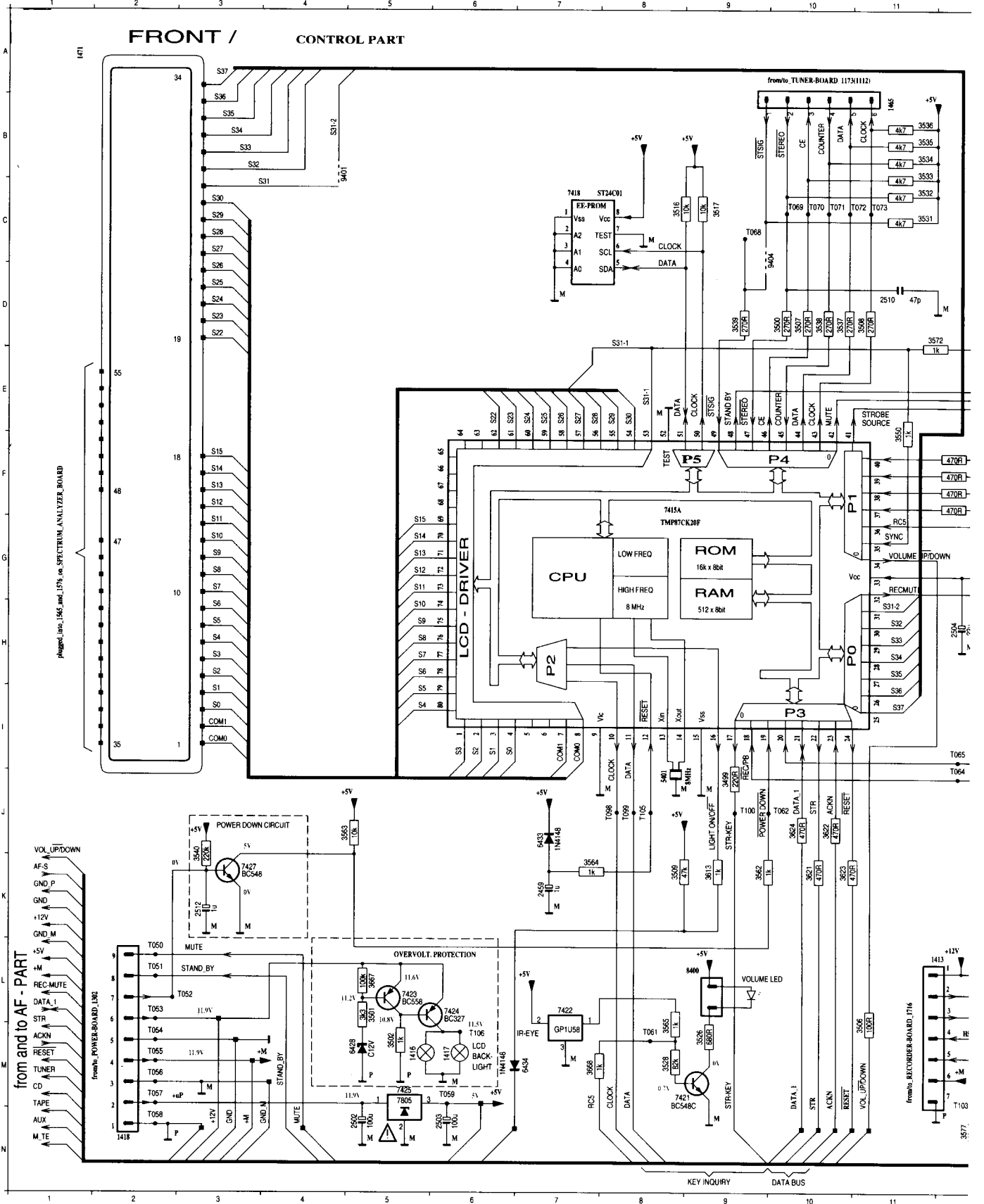

This assembly drawing shows a summary of all possible versions!
For components used in a specific version see schematic diagram respectively partslist.















1413 L12	1420 G18	1429 H16	1435 G17	1442 J16	1448 K16	2502 N 5	2514 E19	3506 L11	3526 M 9	3536 B11	3550 E11	3558 G22	3565 M 8	3576 J14	3582 L14	3590 G21	3596 F	
1418 M 5	1424 H17	1430 H16	1436 K16	1443 J16	1454 D15	2503 N 6	2551 B16	3507 D10	3526 N 8	3530 B11	3553 B15	3559 G22	3568 I12	3577 N12	3583 K14	3591 H21	3597 F	
1417 M 6	1425 H18	1431 H17	1437 J16	1444 J16	1465 A11	2504 H12	2507 I22	3499 J 9	3508 D11	3531 C11	3554 E15	3560 G22	3573 L13	3578 M13	3586 D14	3593 H22	3598 C	
1418 N 2	1426 G16	1432 H18	1438 J17	1445 I16	1471 A 1	2507 I22	2507 I22	3500 D10	3509 K 8	3532 C11	3538 D10	3555 E16	3573 L13	3579 M13	3586 G14	3593 H22	3612 E	
1421 G16	1427 H16	1433 H16	1439 K18	1446 J18	1475 I19	2510 D11	2512 K 3	3501 L 5	3515 C 8	3533 B11	3538 D 9	3558 E17	3574 J14	3580 N14	3587 G15	3594 F12	3613 K	
1422 G17	1428 H18	1434 G16	1440 K17	1447 J17	2459 K 7	2512 K 3	2512 K 3	3502 M 5	3517 C 9	3534 B11	3540 J 3	3557 E18	3564 K 7	3575 L13	3581 M14	3598 H21	3595 F12	3621 K



RECORDER ADJUSTMENT TABLE

Adjustment	Cassette/Source	Recorder mode	Measure on	Read on	Adjust	
					with	to
Azimuth ¹⁾	SBC 420 8kHz	PLAY A-Deck PLAY B-Deck	  or Phone socket	mV - meter	left-hand screw	maximum output left = right
Motor speed ²⁾						
Normal speed	SBC 420 3150Hz	PLAY A + B-Deck HS-Dubbing	  or Phone socket	Wow and Flutter meter or Counter	pot on motor	0±1%
High speed ⁴⁾				Counter	check only	5556-5783Hz

CHECK ONLY

Check	Cassette/Source	Recorder mode	Measure on	Read on	Check if
Wow and Flutter	SBC 420 3150Hz	PLAY A or B-Deck PLAY A and B-Deck	  or Phone socket	Wow and Flutter meter	≤ 0,3% weighted ≤ 0,35% weighted
Erase Oscillator					
Voltage	any	REC A-deck	 Erase head	mV - meter Counter	Cr ≥ 9,8Vrms Fe ≥ 20,8 Vrms
Frequency					f = 60kHz ± 5kHz
Playback level ³⁾	SBC420 315Hz 0dB level	PLAY A-Deck ⁵⁾ PLAY B-Deck ⁵⁾	 	mV - meter	41 mV - 57 mV 41 mV - 57 mV
Frequency response					
Playback	SBC420	PLAY A or B-Deck ⁵⁾	 	mV - meter	125 Hz - 10 kHz within 8dB
Overall	Level = 0,5mV  	REC A-Deck ⁵⁾ PLAY A-Deck ⁵⁾	 	mV - meter	125 Hz - 10 kHz within 8dB 125 Hz - 8 kHz dubbing
Distortion	SBC 420 Level = 10mV  	REC A-Deck ⁵⁾ PLAY A-Deck ⁵⁾	 	mV - meter	50 mV ± 10 mV, D ≤ 5%

SBC 420 Service code: 4822 397 30071

- 1) For Azimuth adjustment set need not to be dismantled. Remove ornamental part of cassette door and put screwdriver (torx5) through holes of cassette door.
- 2) Absolute difference between deck A and deck B have to be ≤2%.
- 3) Noise level in "PAUSE" should be 80 - 180µV (A-weighted).
- 4) Insert SBC420 in A-Deck and use High speed dubbing mode to check frequency.
- 5) Recorder has to be in Fe- Mode

RECORDER BOARD

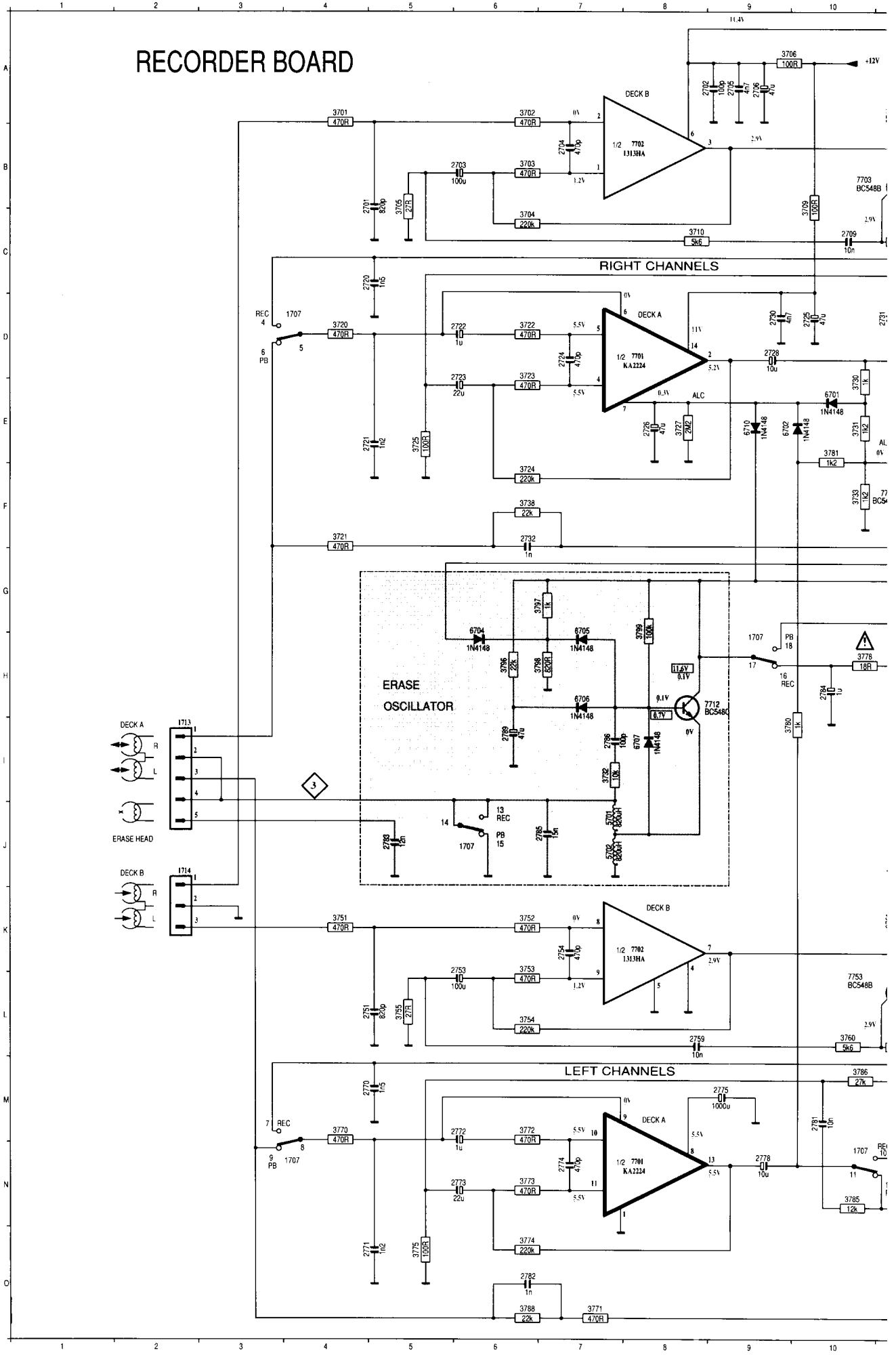

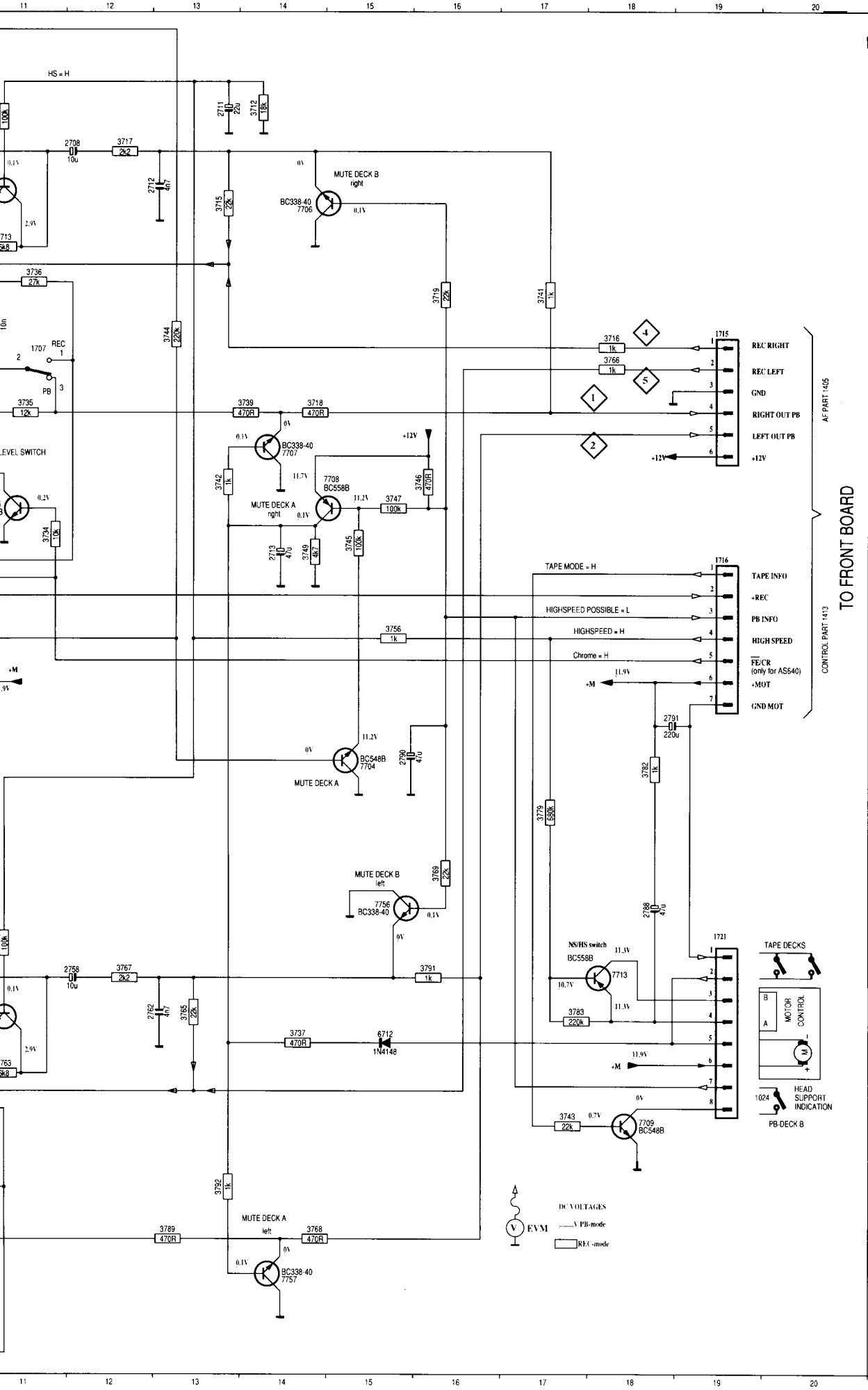

- 1707 D11
- 1707 N4
- 1707 J6
- 1707 G 9
- 1707 D 4
- 1713 J2
- 1714 J2
- 1715 D19
- 1716 F19
- 1721 K19
- 2701 B 5
- 2706 A 9
- 2703 B 6
- 2704 B 7
- 2705 A 9
- 2706 A 9
- 2708 B12
- 2709 C10
- 2711 A13
- 2712 B13
- 2713 F14
- 2720 C 5
- 2721 E 5
- 2722 D 6
- 2723 E 6
- 2724 D 7
- 2725 D10
- 2726 E 8
- 2728 D 9
- 2730 D 9
- 2731 D11
- 2732 F 6
- 2751 L 5
- 2753 L 6
- 2754 K 7
- 2758 K12
- 2759 L 8
- 2762 L13
- 2770 M 5
- 2771 O 5
- 2772 M 6
- 2773 M 6
- 2774 N 7
- 2775 M 9
- 2778 M 9
- 2781 M10
- 2782 O 6
- 2783 J 5
- 2784 H10
- 2785 J 7
- 2786 I 8
- 2788 J18
- 2789 I 7
- 2790 I 5
- 2791 H18
- 3701 A 4
- 3702 A 6
- 3703 B 6
- 3704 C 6
- 3705 B 5
- 3706 A 9
- 3709 B10
- 3710 C 8
- 3711 A11
- 3712 A14
- 3713 C11
- 3715 B13
- 3716 D18
- 3717 B12
- 3718 E14
- 3719 C16
- 3720 D 4
- 3721 F 4
- 3722 D 6
- 3723 E 6
- 3724 F 6
- 3725 E 5
- 3727 E 8
- 3730 I 7
- 3731 E10
- 3732 I 8
- 3733 F10
- 3734 F11
- 3735 E11
- 3736 C11
- 3737 L14
- 3738 F 6
- 3739 E14
- 3741 C17
- 3742 F13
- 3745 M17
- 3744 D13
- 3745 F15
- 3746 F16
- 3747 F15
- 3749 F14
- 3751 K 4
- 3752 K 6
- 3753 K 6
- 3754 L 6
- 3755 L 5
- 3756 G15
- 3760 L10
- 3761 K11
- 3763 L11
- 3765 L13
- 3766 D18
- 3767 K12
- 3768 M14
- 3769 J16
- 3770 M 4
- 3771 O 7
- 3772 M 6
- 3773 N 6
- 3774 O 6
- 3775 O 5
- 3778 H10
- 3779 I 7
- 3780 I 9
- 3781 E10
- 3782 I 8
- 3783 L17
- 3785 M10
- 3788 M10
- 3788 O 6
- 3789 N13
- 3791 K16
- 3792 N13
- 3796 H 6
- 3797 G 7
- 3798 H 7
- 3799 G 8
- 5701 J 8
- 5702 J 8
- 6701 E10
- 6702 E 9
- 6704 H 6
- 6705 H 7
- 6706 H 7
- 6707 I 8
- 6710 E 9
- 6712 L15
- 7701 N 8
- 7701 D 8
- 7702 B 8
- 7702 K 8
- 7703 B10
- 7704 I15
- 7705 F11
- 7706 B14
- 7707 E14
- 7708 F14
- 7709 M18
- 7712 H 9
- 7713 K18
- 7753 K10
- 7756 J15
- 7757 O14

TO FRONT BOARD

AF PART 1405
CONTROL PART 1413

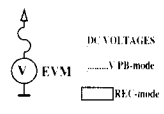
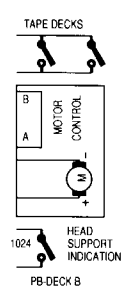

0010	A5	3318	A3
0011	C6	3319	A4
0014	D6	3320	A2
0015	D5	3321	B3
1301	D4	3322	B2
1302	D2	3323	B4
1304	C6	3324	B2
1305	D6	3350	B4
1308	D5	3354	D3
1309	C1	3355	D4
1310	A5	5309	D5
1311	D3	5311	B4
2208	B4	5312	B2
2209	B4	5315	B4
2210	C2	5316	B2
2250	A5	5317	A5
2251	A5	5318	A3
2252	B5	5319	A6
2253	B3	5320	A3
2254	C1	6212	D3
2255	C2	6213	D4
2256	C1	6214	C4
2257	A6	6215	C3
2259	A6	6250	B5
2260	B6	6251	C5
2262	D2	6252	C2
2265	C5	6253	C2
2311	D3	6254	C1
2312	D4	6257	A6
2315	A4	6258	A6
2316	A2	6259	C4
2317	B3	6261	C5
2318	C3	6350	C4
2319	A4	6351	D3
2320	A3	6354	C4
2323	C4	7210	D3
2324	B3	7250	D2
2325	B4	7252	B1
2326	C4	7253	C2
2329	A3	7254	C2
2330	A2	7255	C1
2333	A4	7309	C2
2334	A2	7310	C3
2335	A4	7311	C3
2336	A2	7312	C3
2337	B4	7313	A4
2338	B2	7314	A3
2339	B4	7352	C2
2340	B2		
2350	B3		
2351	D4		
2352	D4		
2353	D4		
2354	C2		
2355	A4		
2356	A2		
2361	C6		
2362	D6		
3213	C4		
3214	C3		
3217	C4		
3218	C3		
3221	D4		
3222	D4		
3223	D4		
3250	C5		
3251	C1		
3252	D2		
3254	C2		
3255	B2		
3256	B2		
3257	C2		
3258	C2		
3259	C2		
3260	C2		
3261	C1		
3262	C1		
3263	C1		
3307	C3		
3308	C3		
3309	D3		
3310	D4		
3311	C3		
3312	C3		
3313	C3		
3314	C3		
3315	C3		
3316	C3		
3317	A4		

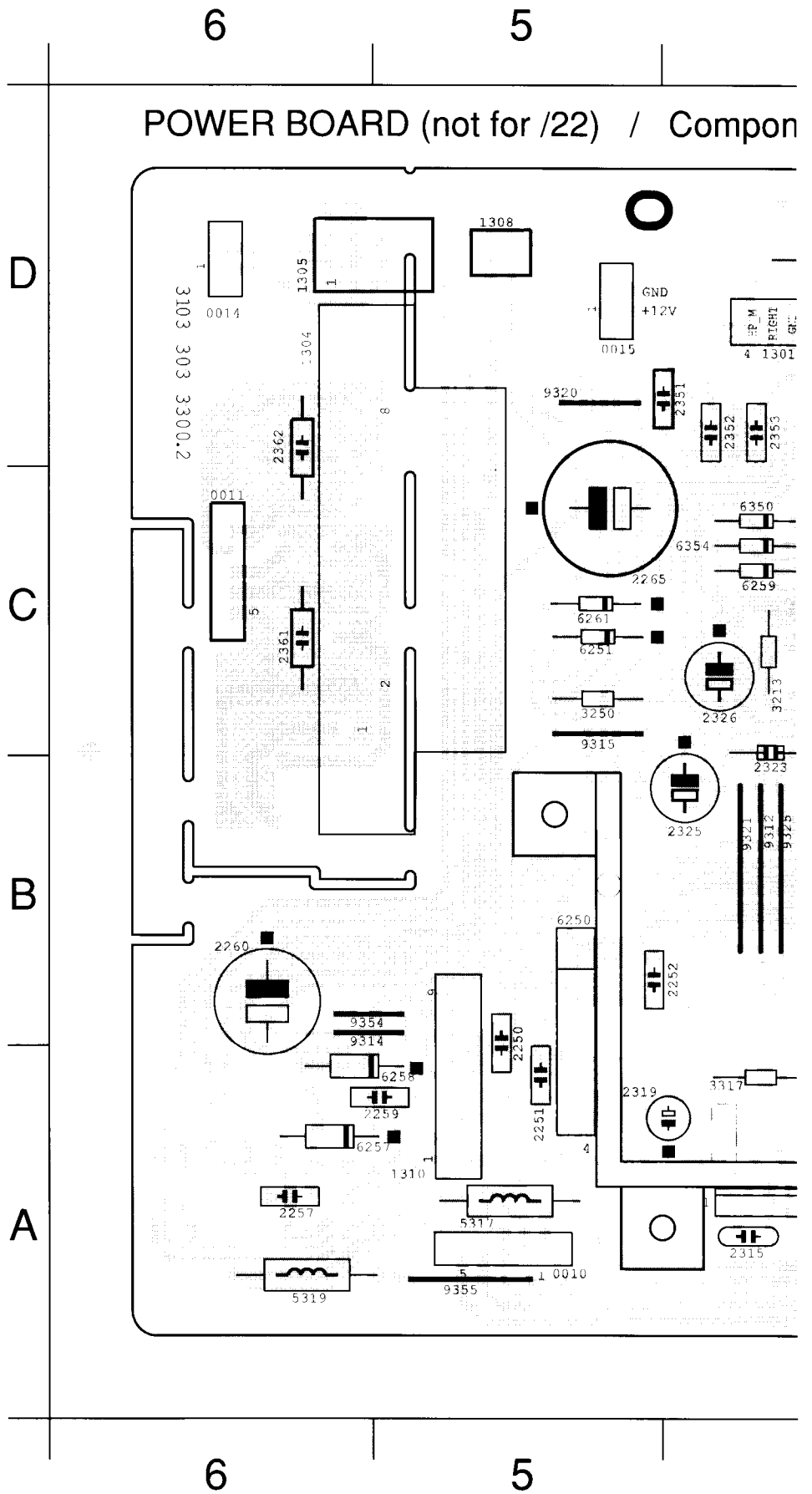

FOR ALL TRANSISTORS

0010	D12	2250	K13	2265	I4	2325	A7	2338	G10	2356	F8	3259	L5	3312	F5	3323	B7
0011	D13	2251	K13	2311	B3	2326	E7	2339	C10	2361	E13	3260	L6	3313	C5	3324	F7
0014	K2	2252	J12	2312	F3	2327	A8	2340	G10	2362	D13	3261	K5	3314	G5	3325	B6
0015	K3	2253	K12	2315	B8	2328	E8	2345	E13	3250	J10	3262	K6	3315	C6	3326	F6
1301	D1	2254	K8	2316	F8	2329	A10	2346	D13	3251	K9	3263	K7	3316	G6	3349	D13
1302	I2	2255	L7	2317	B7	2330	E10	2350	D7	3252	L9	3270	I10	3317	C7	3350	D7
1304	D14	2256	J5	2318	F7	2333	A10	2351	D3	3254	K8	3307	D4	3318	G7	3354	H3
1305	K2	2257	L13	2319	C7	2334	F10	2352	D3	3255	K8	3308	G4	3319	C10	3355	H4
1308	L11	2259	L12	2320	G7	2335	C10	2353	C3	3256	K7	3309	B4	3320	G10	5309	I3
1310	J15	2260	L12	2323	B7	2336	G10	2354	H4	3257	M7	3310	F4	3321	C10	5311	A8
1311	B1	2262	J4	2324	F7	2337	C10	2355	B8	3258	L6	3311	B5	3322	G10	5312	E8

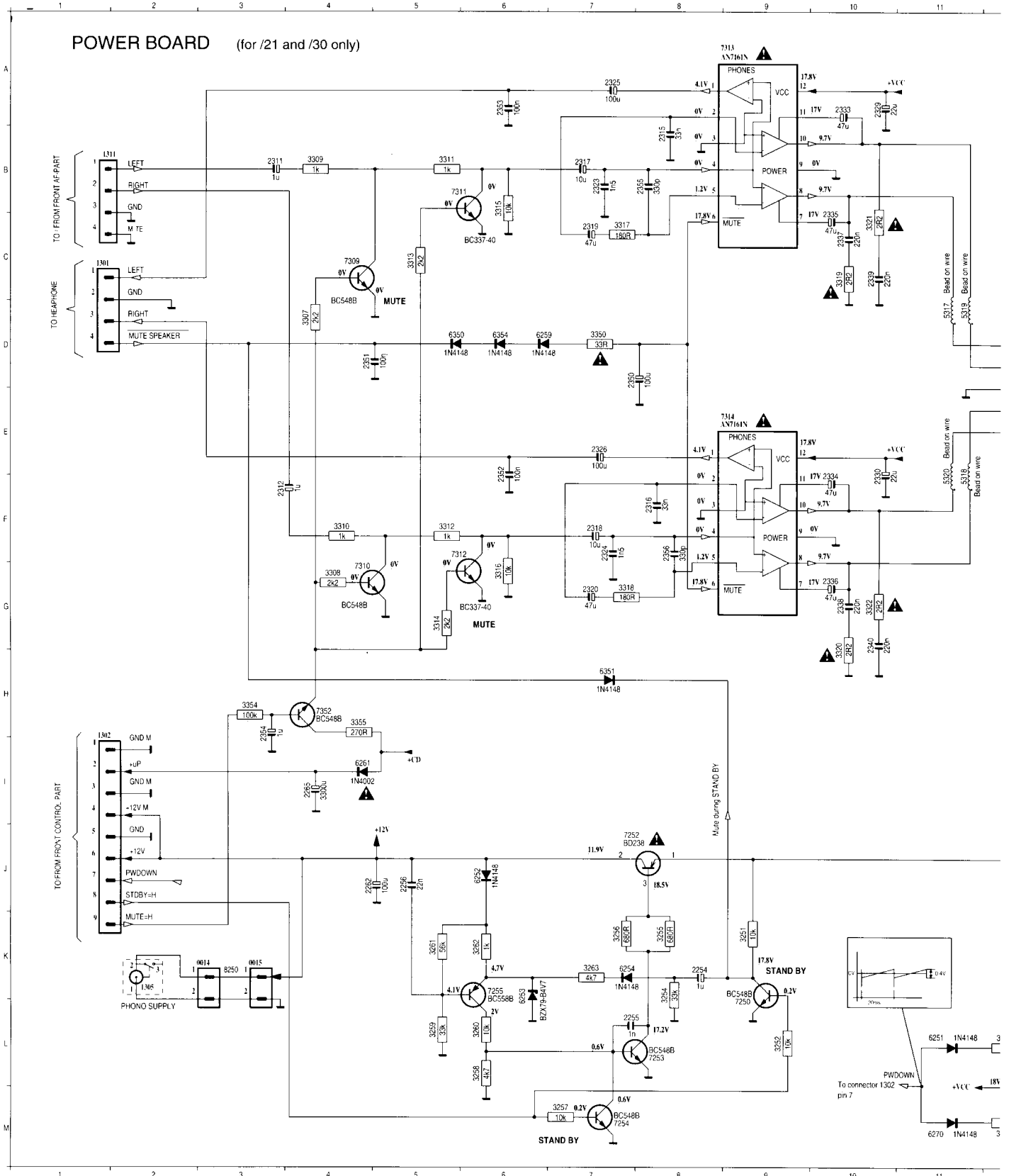

5315	D8	6254	K7	7253	L8
5316	E8	6257	L13	7254	M7
5317	D11	6258	N11	7255	K6
5318	E11	6259	D6	7309	C4
5319	D11	6261	I4	7310	G4
5320	E11	6270	I10	7311	B5
6212	H5	6350	D5	7312	F5
6250	J13	6351	I7	7313	A9
6251	J10	6354	D6	7314	E9
6252	J6	7250	K9	7352	H4
6253	K6	7252	J8		

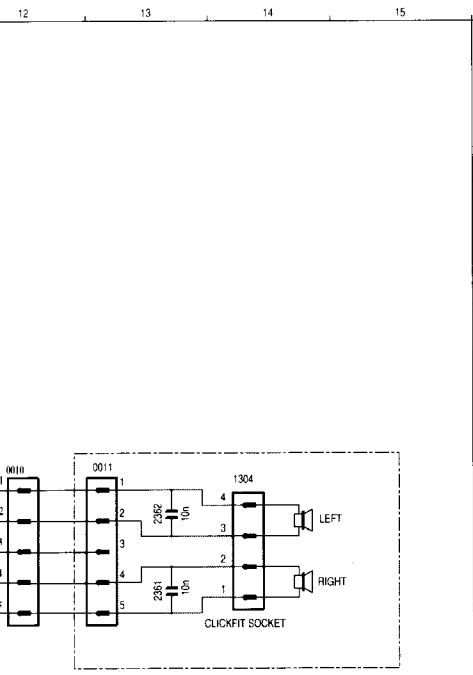

DC Voltages measured in Tuner FM-mode
EVM

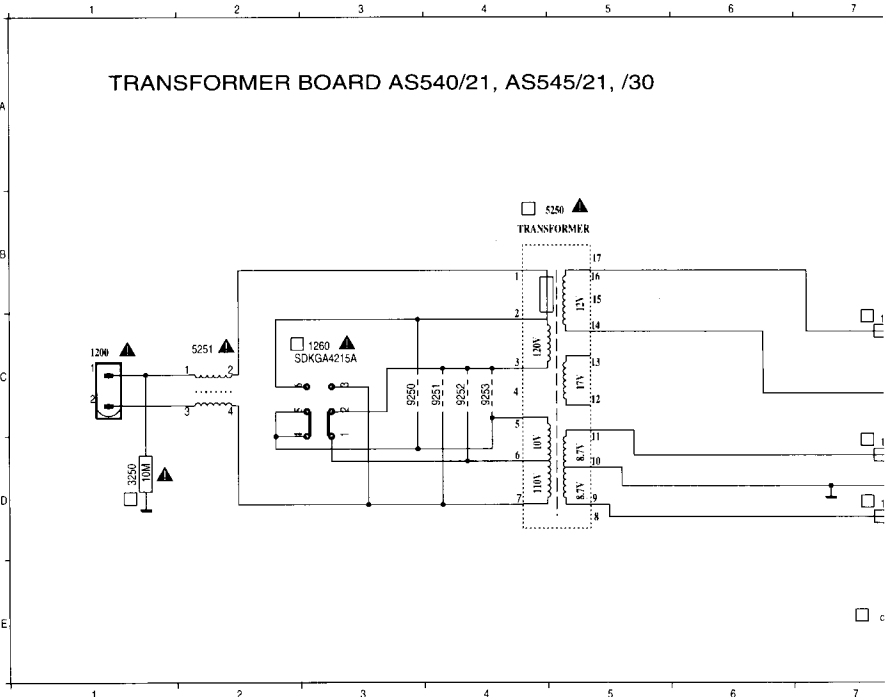
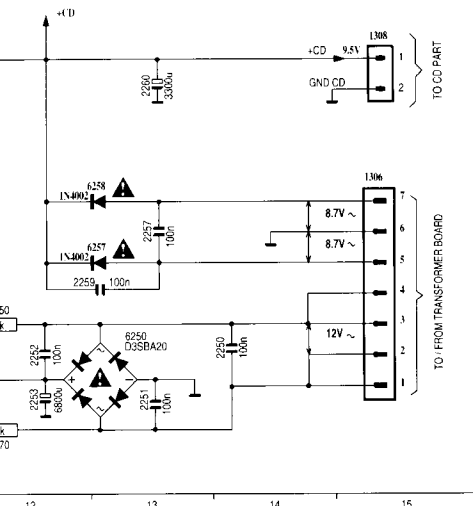

1200 C 1	1251 D 7	9250 B 5	9251 C 4	9255 C 2
1201 B 8	1252 D 7	9251 C 2	9252 C 4	9256 D 2
1250 C 7	1260 C 3	9250 C 3	9253 C 4	

components depending on version

VERSION	COMPONENTS						VALUE OF FUSE				
	<input type="checkbox"/>	3250	1260	9253	9252	9251	9250	9260	1250	1251	1252
/20 (IEC 230V)					X				5A	630mA	630mA
/25 (240V)				X					5A	630mA	630mA
/37 (UL 120V)		X				X	X		6.3A	1.25A	1.25A
/21 /30 (120V 230V)		X						X	5A	630mA	630mA

TRAF0 BOARD Component side view

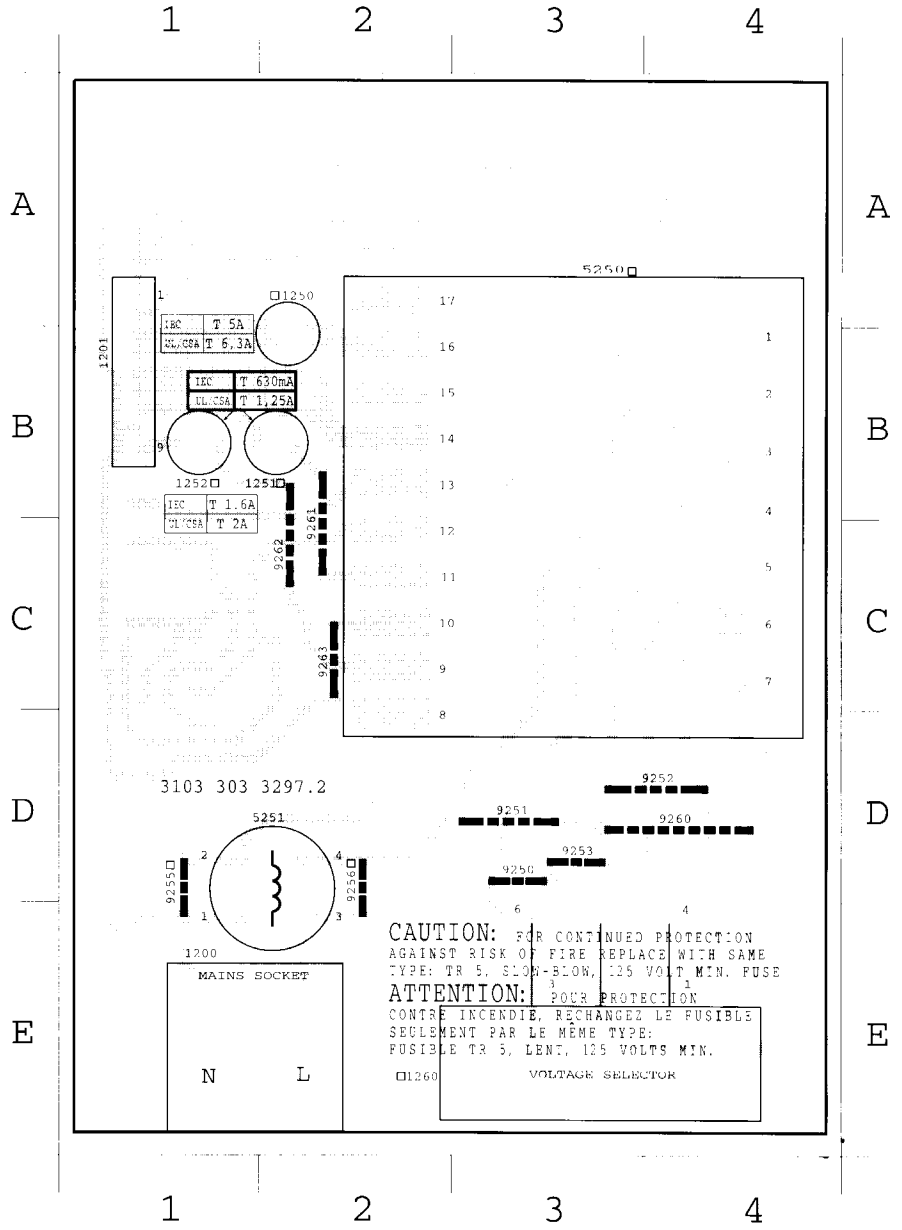
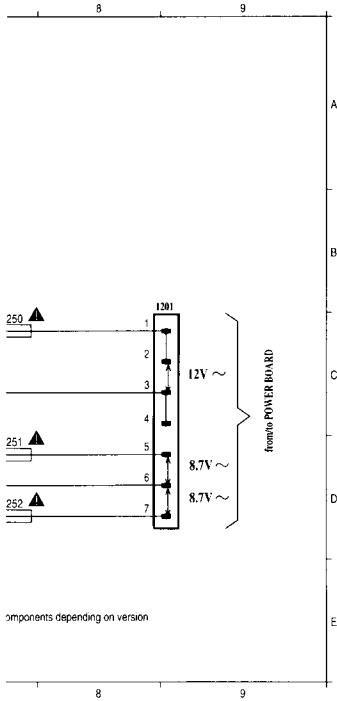

1200 E 1	1252 B 1	9251 D 3	9260 D 1
1201 A 1	1260 E 4	9252 D 4	9261 C 2
1202 C 1	5250 B 3	9253 D 3	9262 C 2
1250 B 2	5251 E 1	9254 E 1	9264 C 2
1251 B 2	9250 D 3	9256 E 2	

TUNER UNIT ECO4-VA (MIDI)

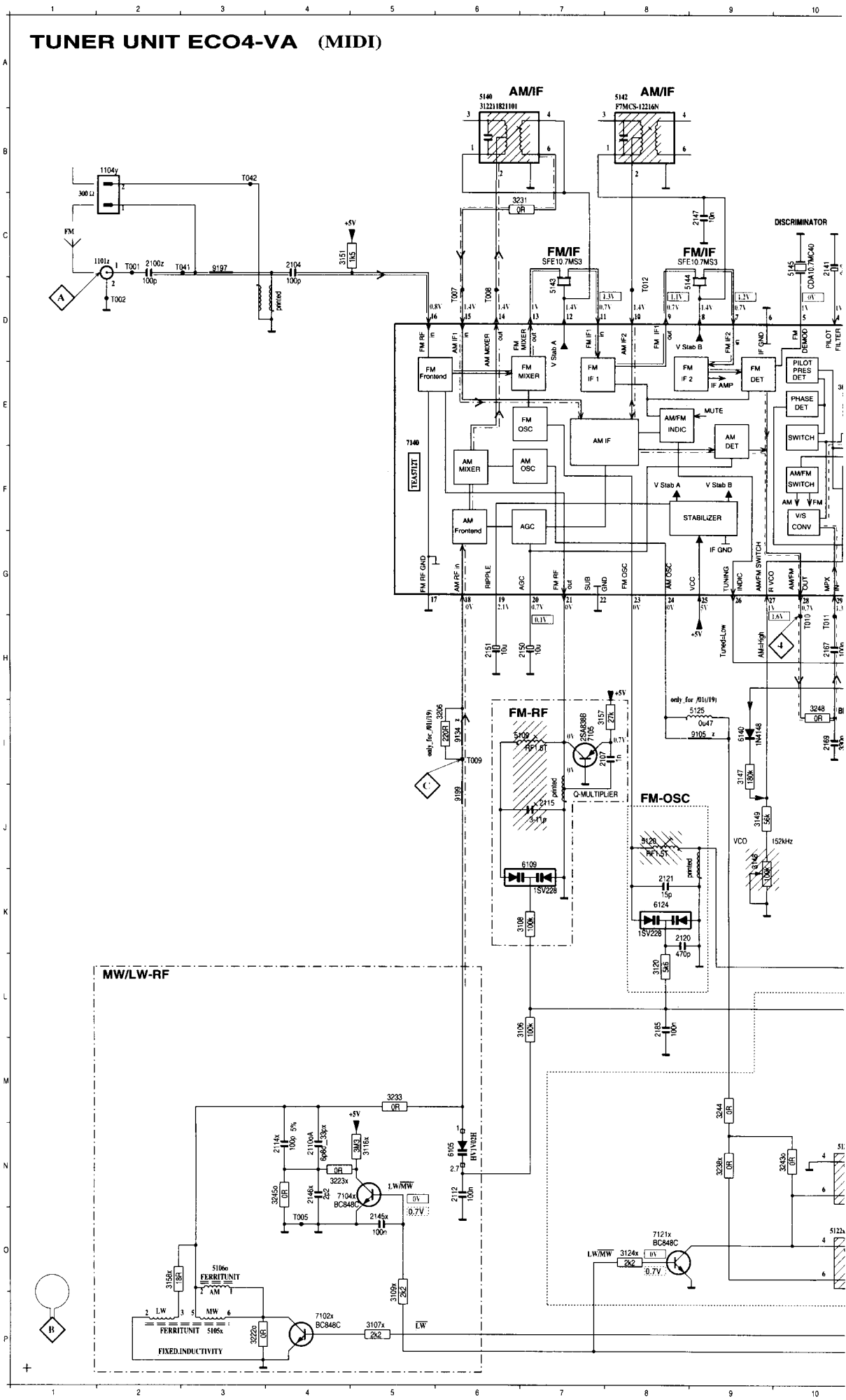

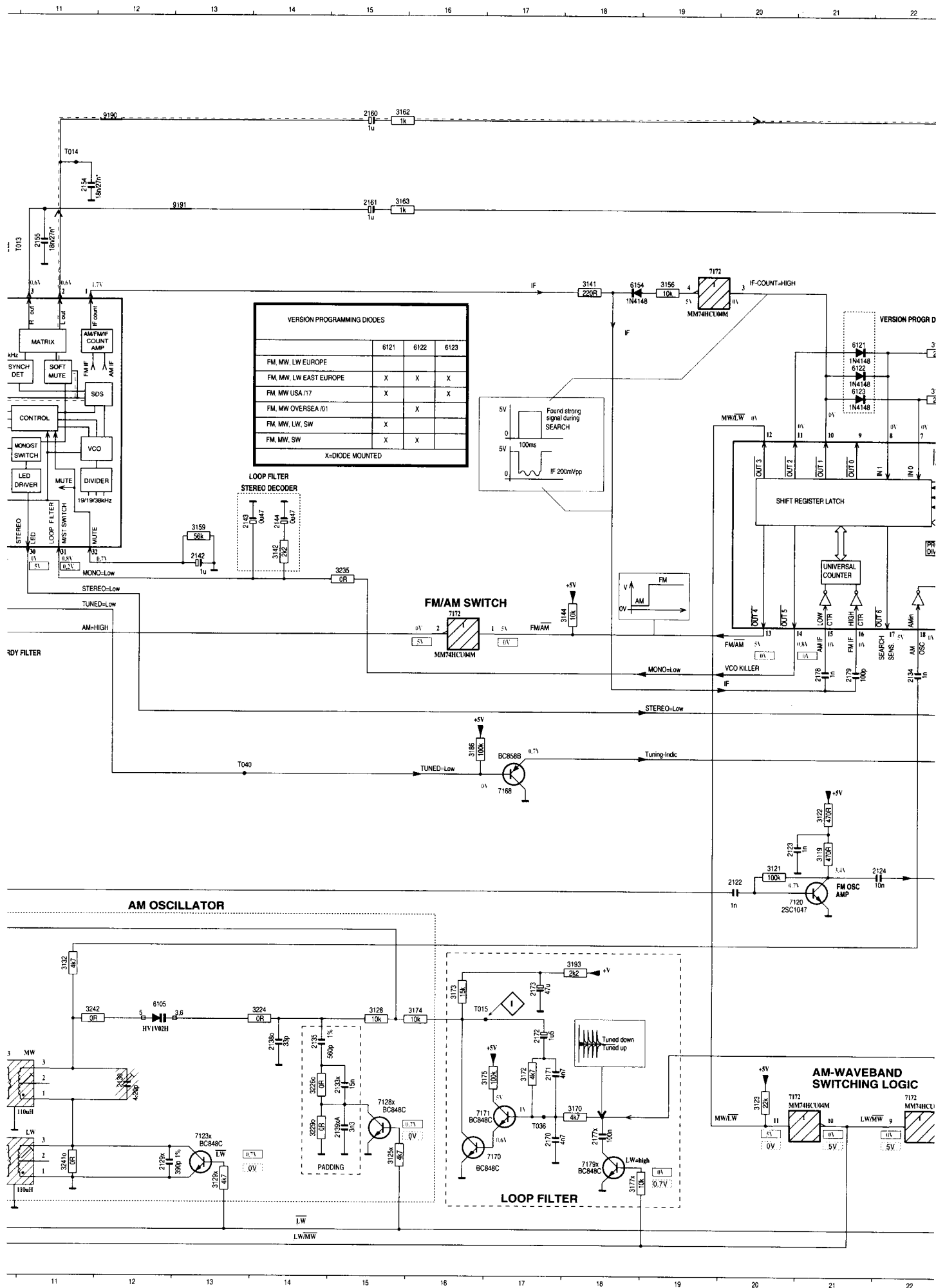

2101	A 2	2122	B 3	2149	D 2	2185	B 3	3109x	A 5	3133	A 5	3157	B 2	3180	D 5	3212	C 5	3233	A 4	3248	C 3	7128x	A 4	7178	C 6
2102	A 4	2123	B 4	2154	C 3	2186	D 6	3110	C 4	3134	A 5	3158x	A 4	3182	C 4	3213	D 5	3234	A 2	6103	A 2	7129	A 5	7179x	A 6
2103	C 2	2125x	A 6	2155	C 3	2187	D 4	3111	D 3	3135	A 6	3159	C 4	3183	D 5	3214	E 3	3235	C 4	6105	B 4	7140	C 2	7180	D 2
2105	B 3	2126x	A 3	2158	D 3	2188	E 4	3113	B 2	3136	E 2	3160	D 4	3184	D 6	3215	E 3	3236o	A 2	6109	B 2	7154	D 3		
2107	B 2	2128	A 5	2159	D 3	2192	E 4	3114	B 3	3137	D 2	3161	D 3	3185	B 6	3216	E 4	3237	B 5	6110	B 4	7155	D 3		
2108	A 3	2132	B 4	2163	D 2	2193	C 4	3116x	A 3	3138	D 2	3166	E 5	3186	C 4	3221	A 4	3238x	A 5	6124	B 3	7167	C 4		
2109	B 4	2133x	A 4	2165	E 2	2194	C 5	3117	A 3	3139	D 2	3167	D 5	3187	C 4	3222o	A 4	3239	D 6	7100	B 2	7168	C 6		
2110o	A 4	2136	B 5	2167	C 3	3100	B 2	3118	A 5	3140	D 2	3168	D 4	3188	C 6	3223x	A 3	3240	D 5	7102x	A 3	7169	C 6		
2111	B 3	2137	B 5	2168	C 3	3101	B 3	3121	B 4	3142	C 4	3169	D 4	3199	D 4	3224	B 4	3241o	A 6	7103	C 4	7170	B 6		
2112	B 4	2138o	B 4	2169	C 4	3102	B 3	3122	B 4	3144	C 5	3171	D 6	3200	C 6	3225	B 4	3242	B 5	7104x	A 3	7171	B 6		
2114x	A 3	2139x	A 4	2171	B 6	3103	C 4	3123	C 5	3145	C 4	3172	B 6	3202	D 3	3226o	A 4	3243o	A 5	7121x	A 6	7172	C 5		
2116	B 2	2145x	A 4	2180	C 6	3104	B 3	3125x	A 5	3147	C 4	3175	B 6	3203	D 3	3228	C 5	3244	A 5	7122	A 5	7173	C 6		
2117	A 4	2146x	A 3	2181	C 6	3106	B 4	3128	B 4	3149	C 3	3176	E 6	3204	D 3	3229o	A 4	3245o	A 3	7123x	B 6	7174	D 5		
2120	B 3	2147	D 3	2182	D 4	3107x	A 5	3129x	B 6	3152	C 1	3178	C 6	3205	D 3	3231	C 2	3246	B 2	7124	B 5	7176	D 4		
2121	B 2	2148	D 2	2183	C 6	3108	B 2	3131	B 5	3153	B 5	3179	C 6	3211	B 6	3232	C 4	3247	B 3	7125	B 5	7177	D 4		

o for AM-version only
x for LW-version only
y for USA version only
z not for all versions

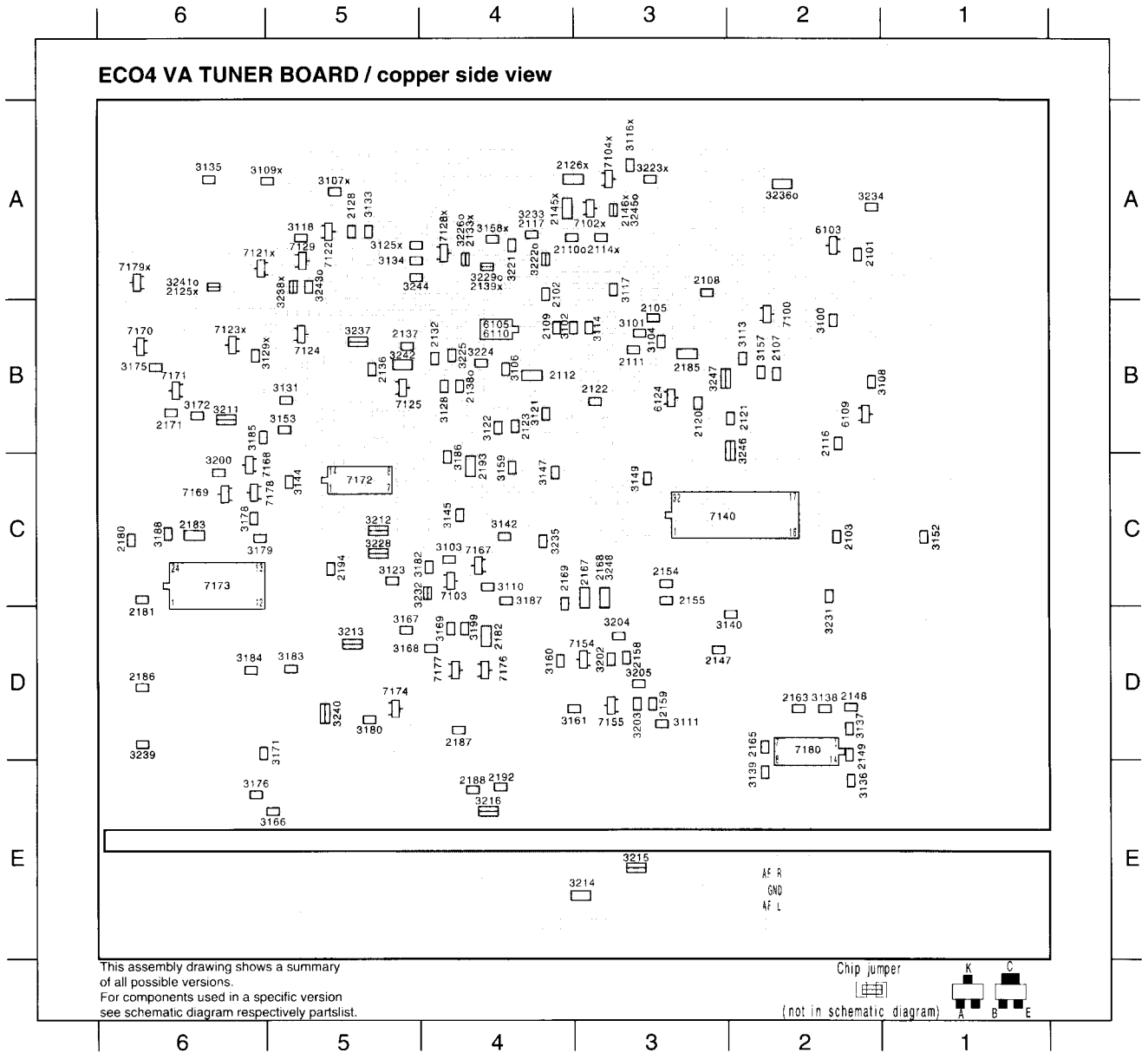

1101 A 1	2100 A 1	2135 B 4	2164 E 2	2191 A 6	3143 D 3	3174 B 5	3198 D 6	5122 B 6	5170 C 6	6140 C 4	7157 E 4	9110 E 5	9123 C 5	9135 D 1
1102 B 1	2104 C 2	2141 D 2	2170 B 6	3105 A 2	3148 C 3	3177 A 6	3206 B 2	5123 B 5	5180 E 3	6154 C 4	7175 D 5	9111 E 5	9124 E 1	9136 D 1
1103 D 1	2106 B 4	2142 C 4	2172 B 6	3112 C 5	3151 D 2	3181 D 5	5101 A 2	5124 B 5	5181 E 3	6170 C 5	9100 F 6	9112 E 4	9125 B 2	9140 C 2
1104 B 1	2113 A 3	2143 C 4	2173 C 6	3115 B 2	3154 D 3	3189 D 6	5102 A 3	5125 B 4	6100 C 1	6174 D 5	9101 F 5	9113 A 5	9126 A 4	9190 D 3
1105 D 1	2115 B 2	2144 C 4	2174 D 2	3119 B 4	3155 D 3	3190 D 6	5103 A 3	5140 D 2	6101 A 2	6180 D 2	9102 A 5	9115 C 5	9127 A 2	9191 D 3
1110 A 1	2118 A 1	2150 C 2	2175 D 2	3120 B 3	3156 C 5	3191 D 6	5104 A 3	5142 D 2	6106 B 3	6181 D 2	9103 C 6	9116 C 5	9128 D 4	9197 C 1
1111 D 2	2119 A 2	2151 C 2	2177 C 6	3124 A 6	3162 E 4	3192 D 6	5105 A 4	5143 C 2	6107 B 3	6182 E 3	9104 E 5	9117 A 6	9129 C 5	9198 A 2
1112 D 5	2124 B 5	2152 D 3	2178 C 5	3126 A 6	3163 E 4	3193 D 6	5106 A 4	5144 C 2	6120 D 6	7101 B 3	9105 B 4	9118 A 2	9130 E 5	9199 A 3
1152 E 5	2129 B 6	2153 D 4	2179 C 5	3127 A 6	3164 D 4	3194 D 5	5107 A 3	5145 D 3	6121 D 5	7105 B 2	9106 C 5	9119 B 5	9131 E 6	a for AM-version only
1155 E 2	2130 B 5	2160 E 3	2184 D 5	3130 B 6	3165 D 4	3195 D 5	5108 A 2	5146 D 2	6122 D 5	7120 B 4	9107 B 5	9120 B 2	9132 C 3	x for LW-version only
1156 E 1	2131 E 3	2161 D 3	2189 E 3	3132 B 6	3170 C 6	3196 D 4	5109 B 2	5150 D 3	6123 D 6	7127 A 5	9108 D 4	9121 A 2	9133 D 1	y for USA version only
1170 E 6	2134 C 6	2162 D 2	2190 A 2	3141 C 3	3173 B 6	3197 D 5	5120 B 3	5151 C 3	6125 B 5	7156 D 4	9109 E 5	9122 B 4	9134 B 2	z not for all versions

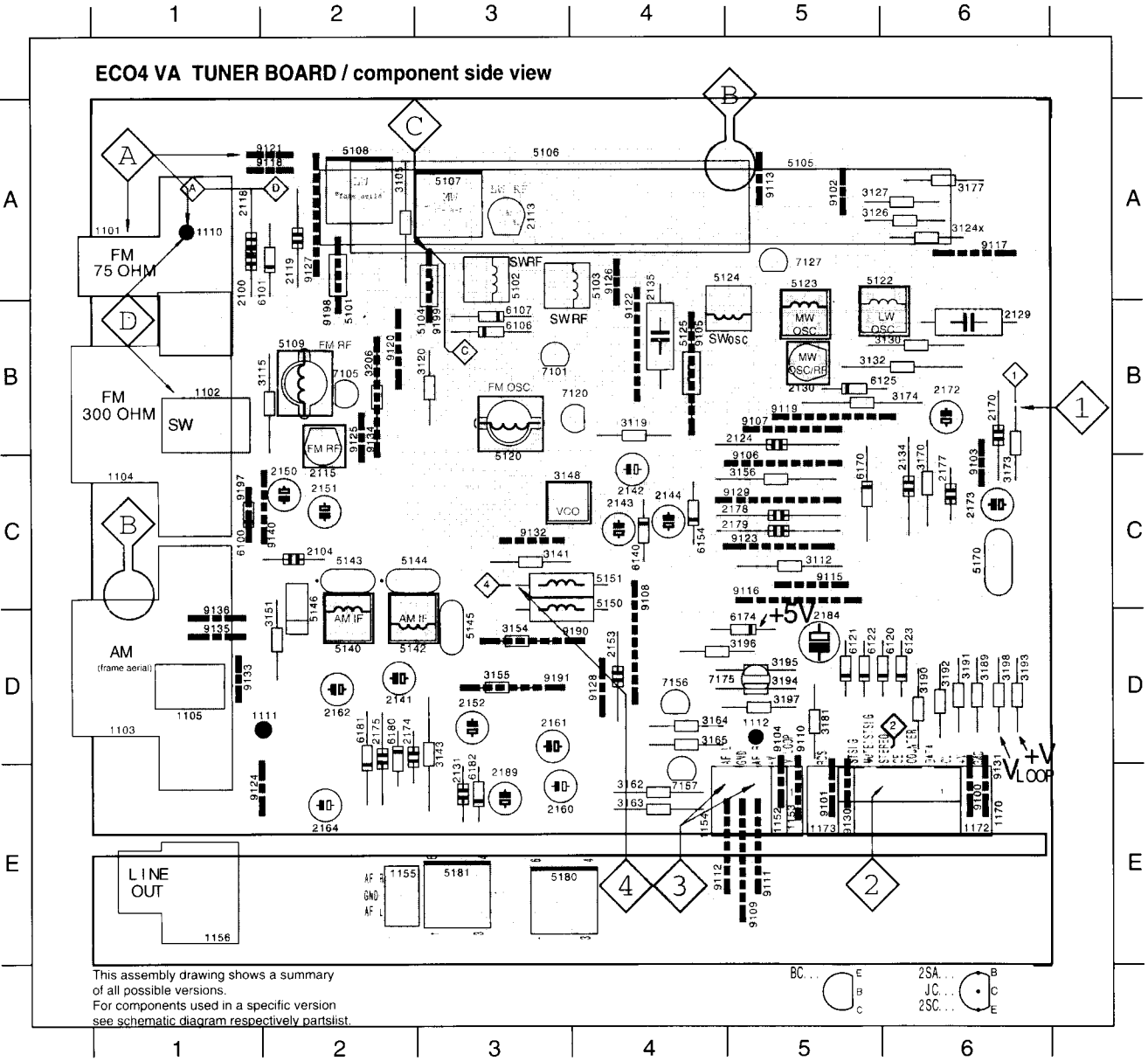

TUNER Adjustment table (ECO4 VA FM/MW- and FM/MW/LW - versions with AM-ferrite antenna)

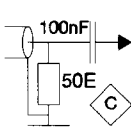
Waverange	Input frequency	Input	Set tuned to	Adjust	Output	Scope / Voltmeter
<i>VARICAP ALIGNMENT * 1)</i>						
FM 87.5 - 108MHz			108 MHz	5120	1	8V ± 0.2V
			87.5MHz	check		4.1V ± 0.5V
FM /14 East Europe 65.81 - 108MHz			108 MHz	5120		8V ± 0.2V
			65.81 MHz	check		0.8V ± 0.4V
MW 2-band version, 10kHz grid 530 - 1710kHz			1710kHz	5123		9V±0.1V (7.2±1.2V) ¹⁾
			530kHz	check		1V±0.4V (1.1±0.5V) ¹⁾
LW 153 - 279kHz			279kHz	5122		8V±0.2V (7.5±1.5V) ¹⁾
			153kHz	check		1V±0.4V (1.1±0.5V) ¹⁾
MW 3-band version 522 - 1611kHz			1611kHz	5123		8V±0.1V (7.2±1.2V) ¹⁾
			522kHz	check		1V±0.4V (1.1±0.5V) ¹⁾
<i>FM - RF</i>						
FM	108MHz	A mod=1kHz Δf=22.5kHz	108MHz	2115	3	MAX ↕
	87.5MHz		87.5MHz	5109		
FM /14 East Europe	108MHz		108MHz	2115		
	65.81MHz		65.81MHz	5109		
<i>VCO</i>						
FM	98 MHz, 1mV continuous wave	A	98MHz	3148	2	152kHz ± 1kHz
<i>AM - IF</i>						
MW	540kHz Δf = 10kHz as low as possible		540kHz	5142 5140	4	symmetrical and max height
<i>AM - RF</i>						
LW	198kHz	B mod=1kHz 30% AM	198kHz	5122	4	MAX
MW 3-band version	1494kHz		1494kHz	2130		MAX
	549kHz		549kHz	5123		
MW 2-band version, 10kHz grid	1500kHz		1500kHz	2130		MAX ↕
	550kHz		550kHz	5123		

* Use Service Test Program. By selecting the TUNER TEST, test frequencies will be stored as preset frequ. automatically.

1) Adjustment of AM-RF stage influences the varicap voltage. Therefore check if varicap voltage fulfils value stated within brackets after AM-RF adjustment.

↕ repeat

402	B 2	2901	C 4	2904	E 5	2907	C 7	2910	C 9	2913	E 0	2916	C 12	2919	B 9	3902	D 5	3905	C 7	3908	B 10	3911	D 10	7900	C 10	1003	C 9	1006	C 9		
901	C 13	2902	C 5	2905	C 6	2908	C 8	2911	D 10	2914	D 11	2917	B 11	3900	C 3	3903	D 6	3906	C 9	3909	A 10	3912	E 10	1001	C 10	1004	A 11	1007	A 11	1008	C 13
2902	C 3	2903	F 5	2906	C 6	2909	D 9	2912	D 10	2915	C 12	2918	B 10	3901	C 4	3904	A 7	3907	B 9	3910	A 12	7900	C 6	1002	C 10	1005	C 10	1008	C 13		

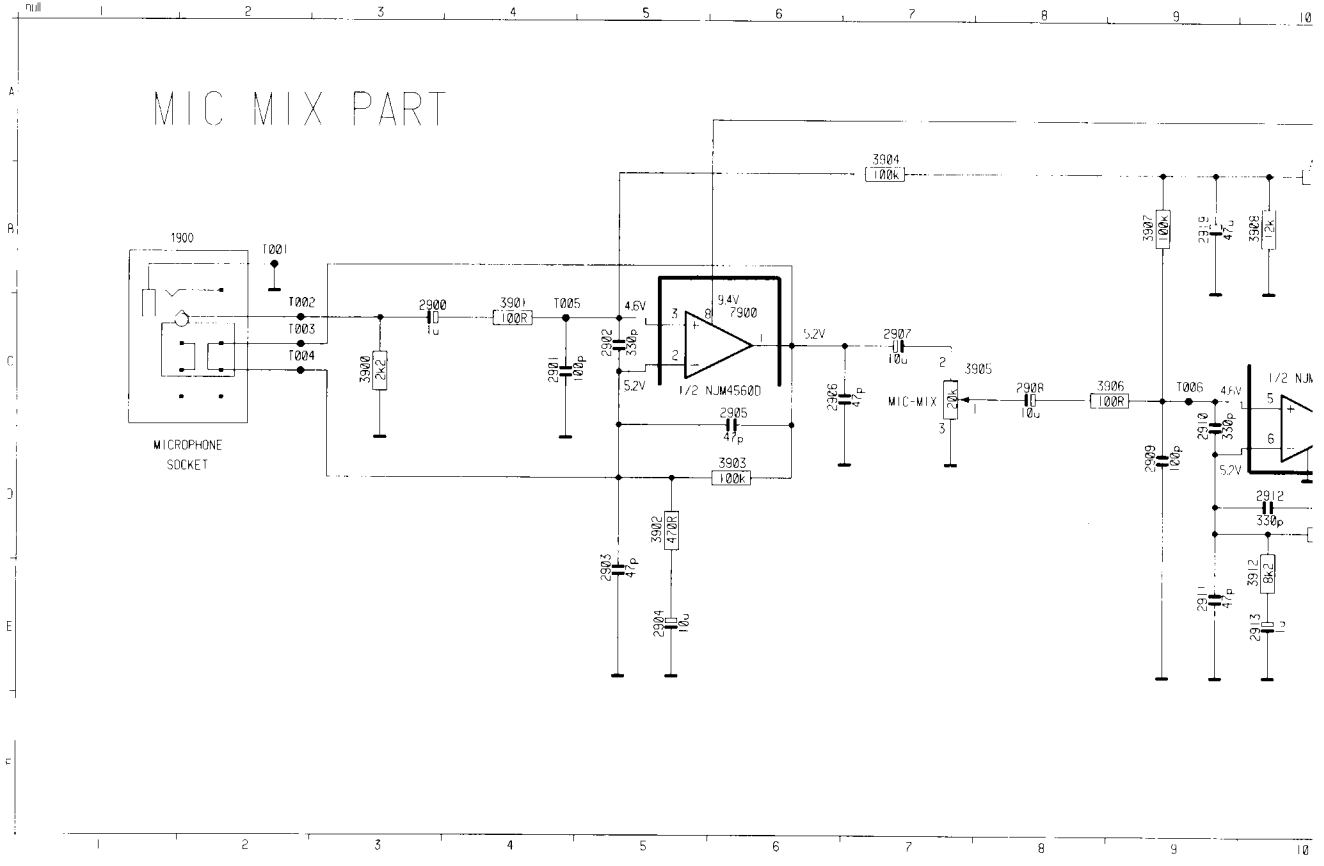

1000	B 1	2005	A 3	2912	B 3	2010	B 3	3906	C 2	7900	B 2
1901	C 3	2906	A 2	2913	C 3	3900	A 2	3907	B 2	9000	B 2
2000	C 2	2907	C 1	2914	B 2	3901	B 3	3908	B 3	9001	C 2
2001	A 2	2908	C 2	2915	C 3	3902	A 2	3909	C 2	9002	A 2
2002	A 2	2909	B 2	2916	C 3	3903	A 3	3910	C 2		
2003	A 2	2910	B 2	2917	C 2	3904	B 3	3911	B 3		
2004	A 3	2911	B 2	2918	B 3	3905	A 1	3912	C 3		

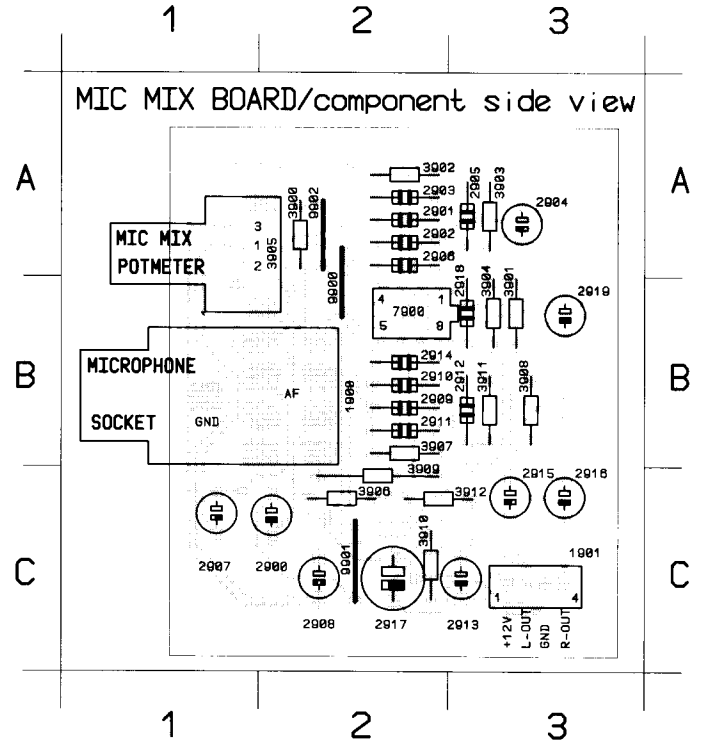

T009 C13
T010 C13
T011 C13

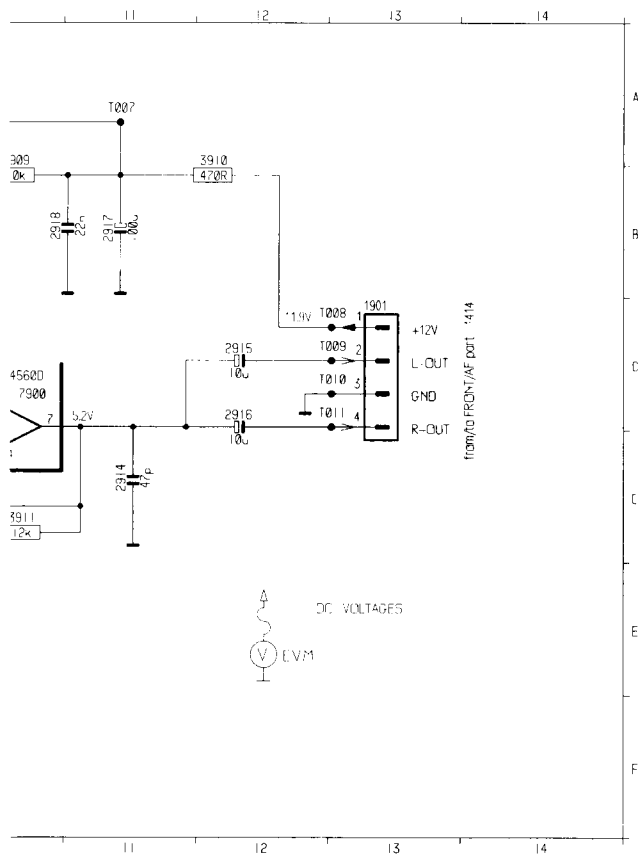

1549	E 1	2550	D 2	2554	D 7	3560	F 2	3563	D 3	3566	D 5	3569	F 5
1565	A 6	2552	F 3	2555	D 7	3561	F 2	3564	D 3	3567	F 5	3573	F 8
1576	A 1	2553	F 3	2556	D 8	3562	D 3	3565	D 5	3568	F 5	3574	F 8

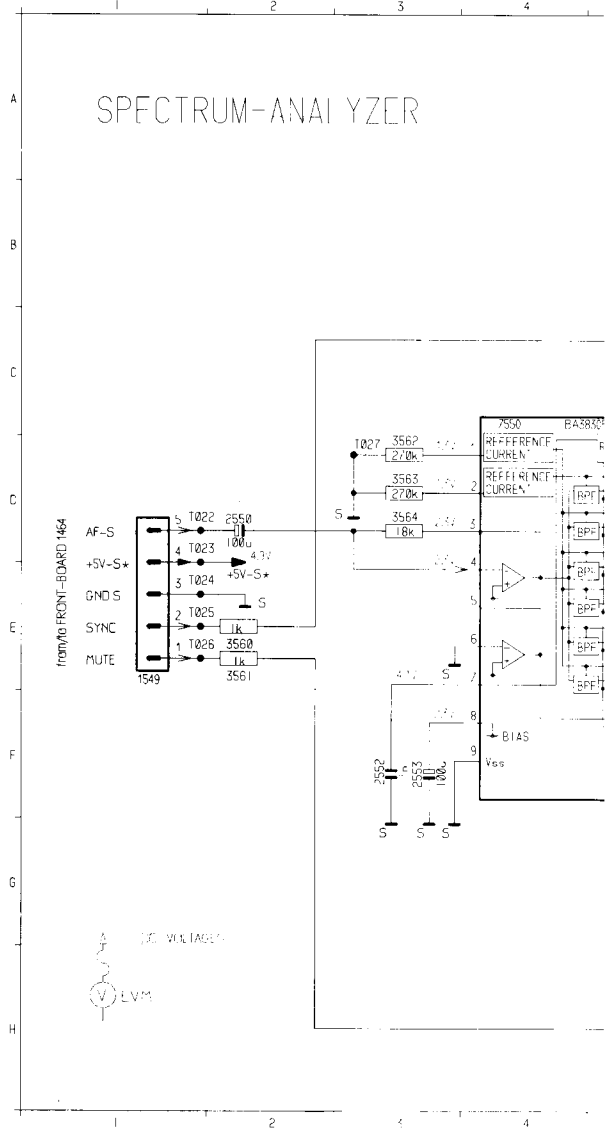

1549	A 5	2553	B 1
1585	A 3	2554	B 2
1576	A 4	2555	B 3
2550	B 1	2556	B 4
2552	A 1	3560	B 3

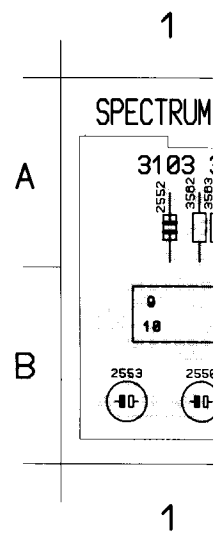

BLOCKDIAGRAM CD Module

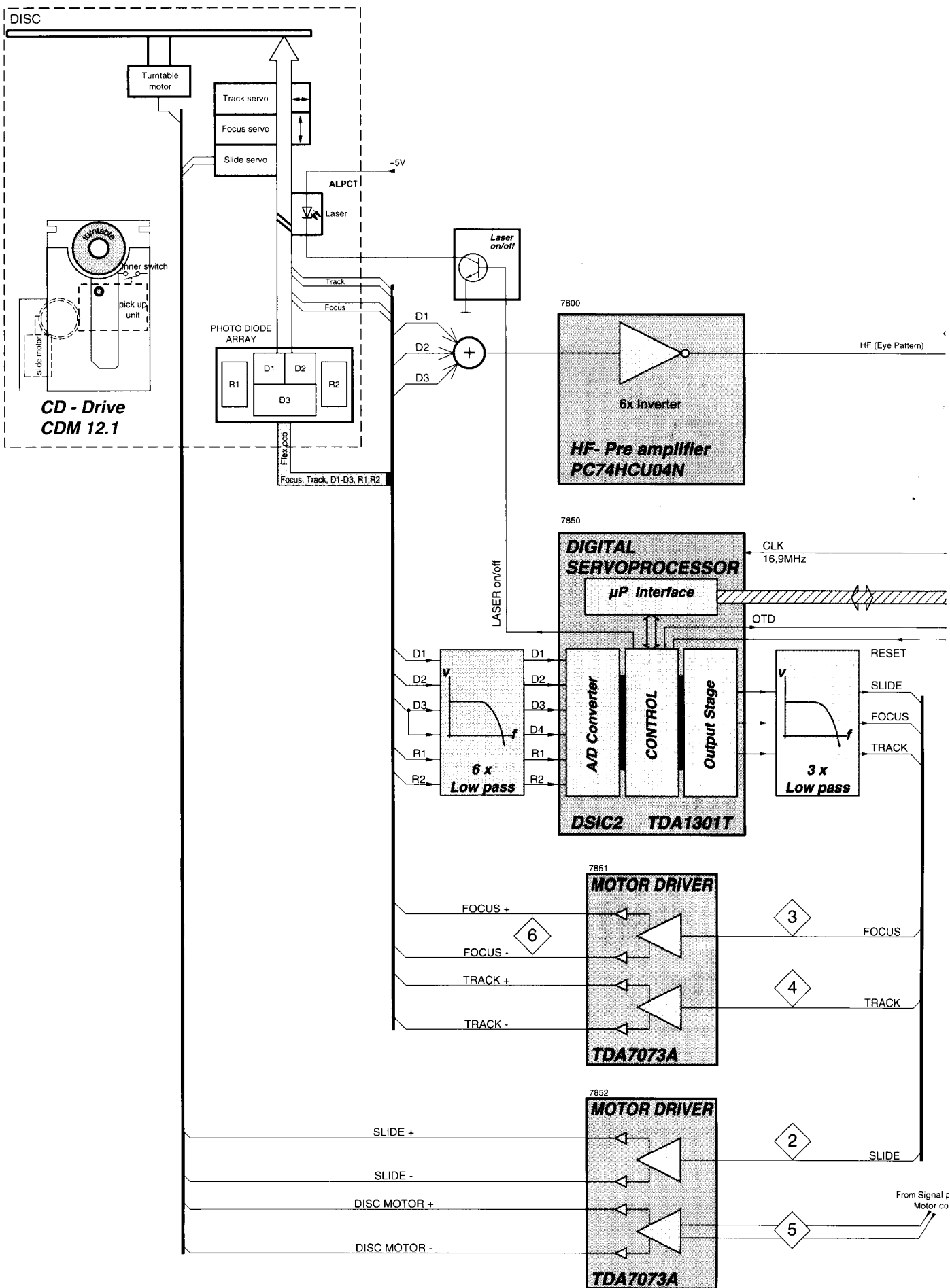

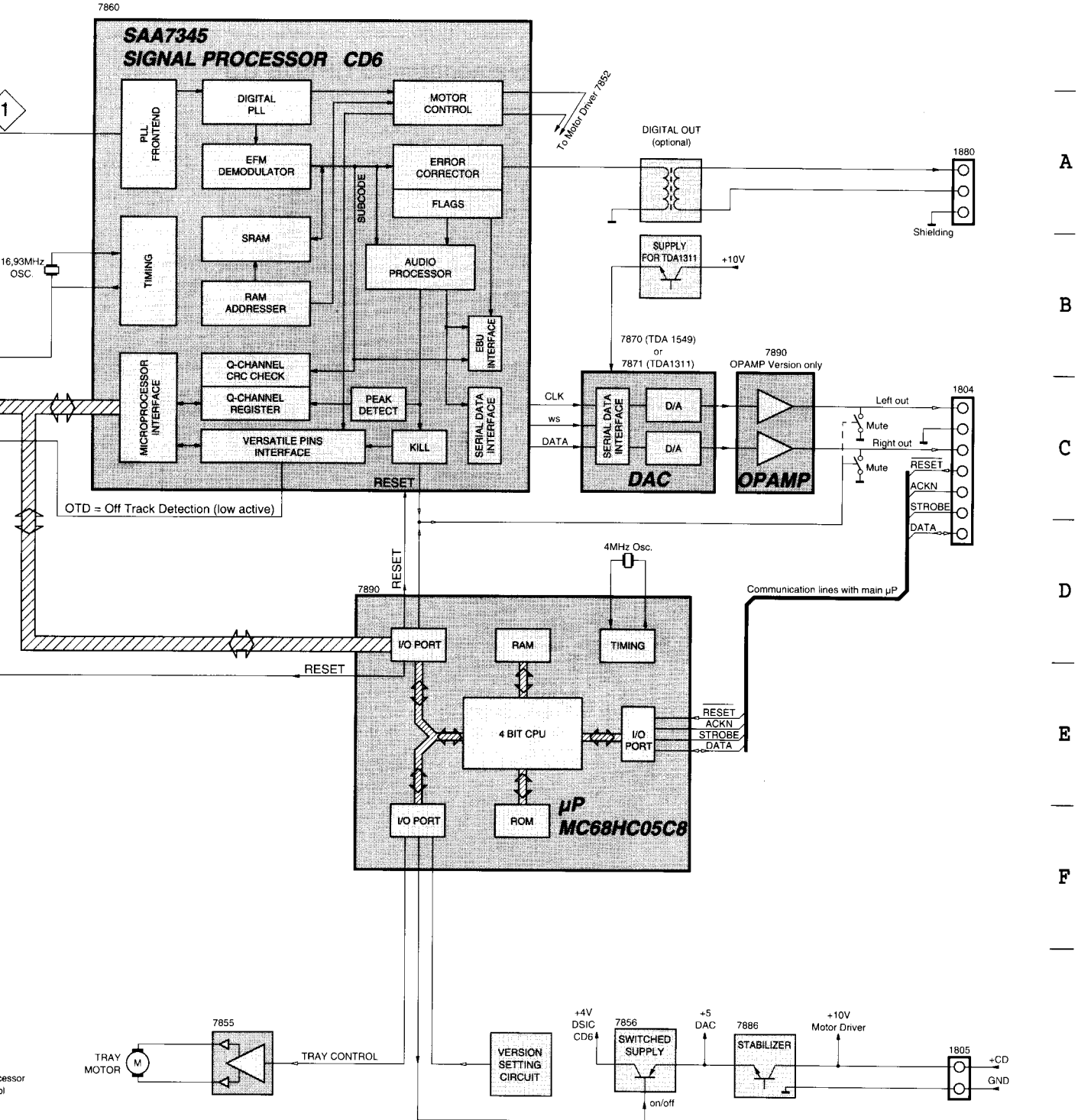

A
B
C
D
E
F

1801 J2	1806 O2	2752 C21	2764 G19	2803 C3	2807 C6	2811 C5	2821 H6	2825 H8	2829 H10
1802 N18	1810 J30	2753 F18	2769 B26	2804 C3	2808 C7	2814 D11	2822 H5	2826 H9	2830 H10
1804 F32	1820 J30	2762 G19	2770 D26	2805 D3	2809 D9	2818 I4	2823 H6	2827 H9	2831 H14
1805 G32	1880 A12	2763 G19	2802 B9	2806 D4	2810 C11	2820 H7	2824 H6	2828 H9	2833 J10

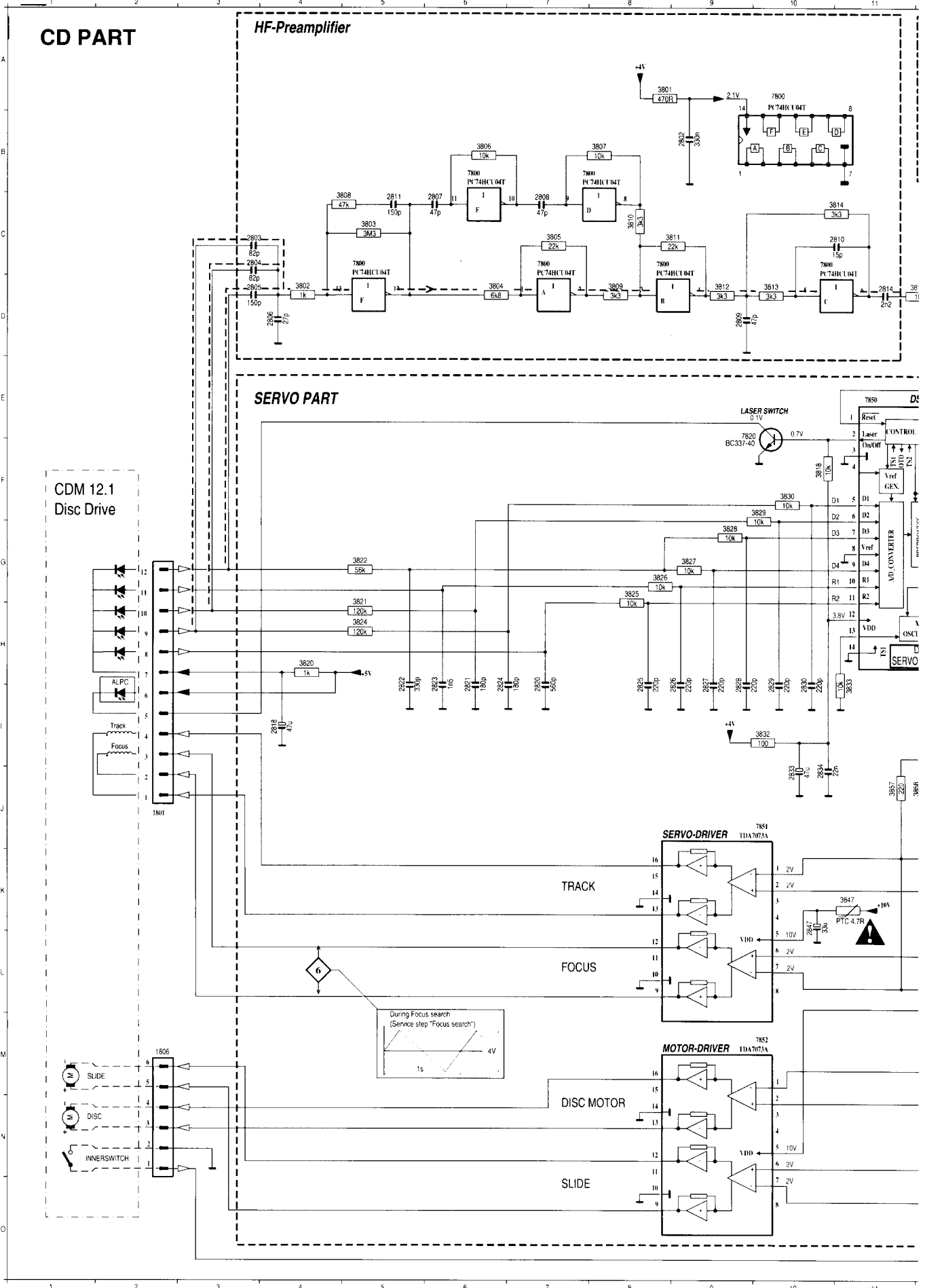

2834	J10	2839	L13	2848	A16	2852	G18	2857	E16	2861	G17	2867	A24	2879	B31	2889	A14	2893	O30
2836	K13	2840	L12	2849	M16	2853	O13	2858	E16	2862	G17	2876	E29	2881	G29	2890	B14	2894	O30
2837	K12	2843	M12	2850	J14	2854	F32	2859	F16	2864	A25	2877	B29	2883	G30	2891	H27	2895	O30
2838	H14	2847	L10	2851	O12	2856	D16	2860	F16	2866	A25	2878	E31	2888	B12	2892	H28	2897	H25

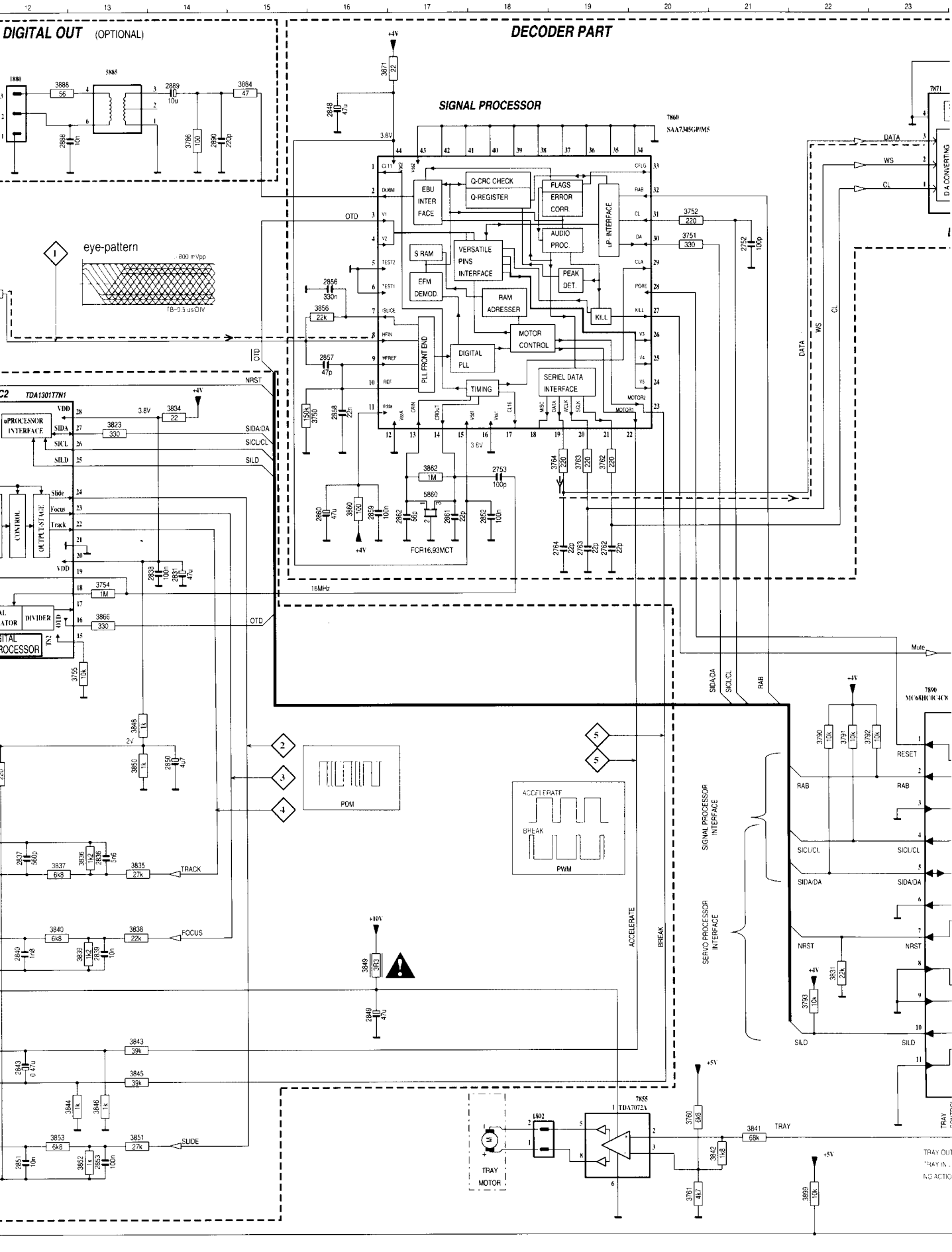

3750	E16	3755	H13	3763	F19	3785	H28	3792	I22	3801	A8	3805	C7	3809	D8	3813	D10	3820	H4
3751	C20	3760	N20	3764	F19	3786	B14	3793	M22	3802	D4	3806	B6	3810	C8	3814	C11	3821	H5
3752	C20	3761	O20	3767	A29	3790	I22	3794	L29	3803	C5	3807	B8	3811	C9	3815	D12	3822	G5
3754	G13	3762	F19	3770	D29	3791	I22	3795	L29	3804	D6	3808	C5	3812	D9	3818	F10	3823	E13

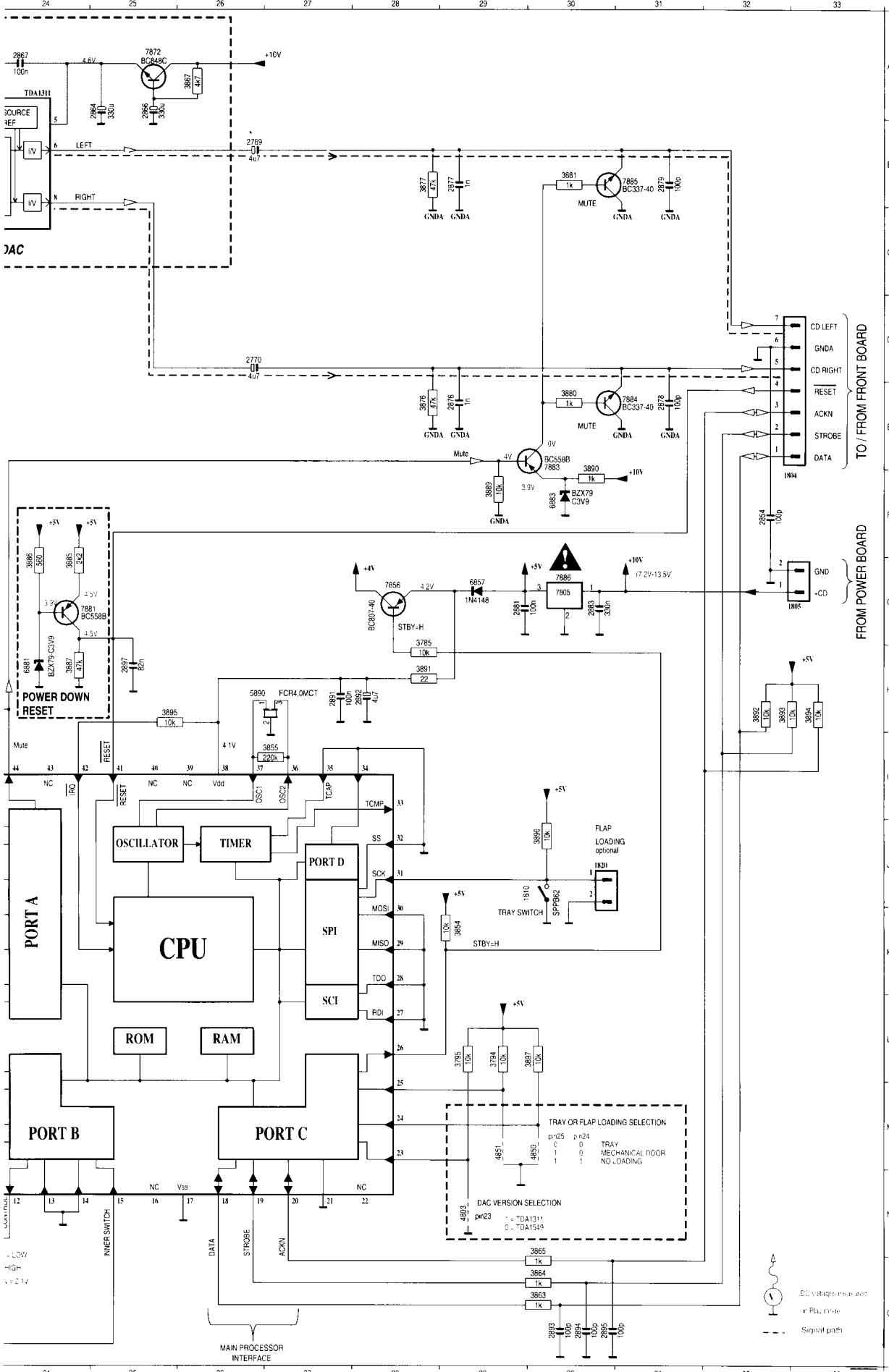

3824	H5	3825	G8	3826	G8	3827	G9	3828	G9	3829	F10	3830	F10	3831	L22	3832	I10	3833	H11	3834	E14	3835	K13	3836	K13	3837	K12	3838	L13	3839	L13	3840	L12	3841	N21	3842	N21	3843	M13	3844	N12	3845	N13	3846	N13	3847	K11	3848	I13	3849	L16	3850	J13	3851	N13	3852	O13	3853	N12	3854	K29	3855	I27	3856	D16	3857	J11	3858	J12	3860	F16	3862	F17	3863	O30	3864	O30	3865	O30	3866	H13	3867	A26	3871	A16	3876	E28	3877	B28	3880	E30	3881	B30	3884	A15	3885	G24	3886	G24	3887	H24	3888	A12	3889	F29	3890	F30	3891	H28	3892	H32	3893	H32	3894	H33	3895	H25	3896	J30	3897	L30	3899	O22	4803	N29	4850	M30	4851	M29	5860	F17	5885	A13	5890	H26	6857	G29	6881	H24	6883	F30	7800	D5	7800	B7	7800	B6	7800	C10	7800	C8	7800	C7	7820	E10	7850	E11	7851	J9	7852	M9	7855	N20	7856	G28	7860	B20	7871	A23	7872	C24	7880	D27	7880	A27	7881	G24	7883	C30	7884	E31	7885	B31	7886	G30	7890	I23
------	----	------	----	------	----	------	----	------	----	------	-----	------	-----	------	-----	------	-----	------	-----	------	-----	------	-----	------	-----	------	-----	------	-----	------	-----	------	-----	------	-----	------	-----	------	-----	------	-----	------	-----	------	-----	------	-----	------	-----	------	-----	------	-----	------	-----	------	-----	------	-----	------	-----	------	-----	------	-----	------	-----	------	-----	------	-----	------	-----	------	-----	------	-----	------	-----	------	-----	------	-----	------	-----	------	-----	------	-----	------	-----	------	-----	------	-----	------	-----	------	-----	------	-----	------	-----	------	-----	------	-----	------	-----	------	-----	------	-----	------	-----	------	-----	------	-----	------	-----	------	-----	------	-----	------	-----	------	-----	------	-----	------	-----	------	-----	------	-----	------	-----	------	-----	------	----	------	----	------	----	------	-----	------	----	------	----	------	-----	------	-----	------	----	------	----	------	-----	------	-----	------	-----	------	-----	------	-----	------	-----	------	-----	------	-----	------	-----	------	-----	------	-----	------	-----	------	-----

Dismantling hints CD Short Loader

Dismantling the tray

- a) Press open/close button to open the tray. If the tray doesn't work, use a small screw driver as shown in Fig. 1 point 1 to move the tray outside. After the first centimeter it is possible to pull the tray out by hand.
- b) Release two snaps and remove tray.

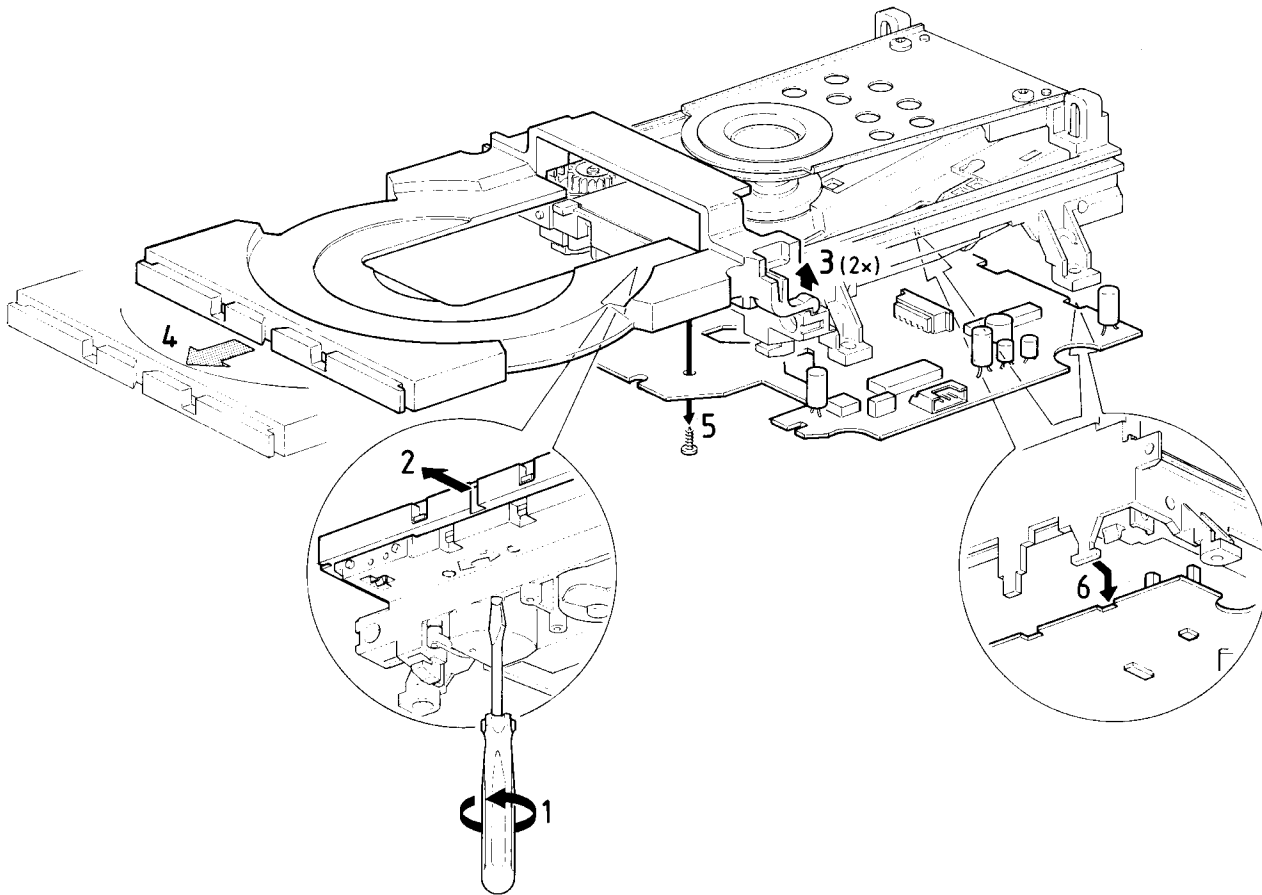
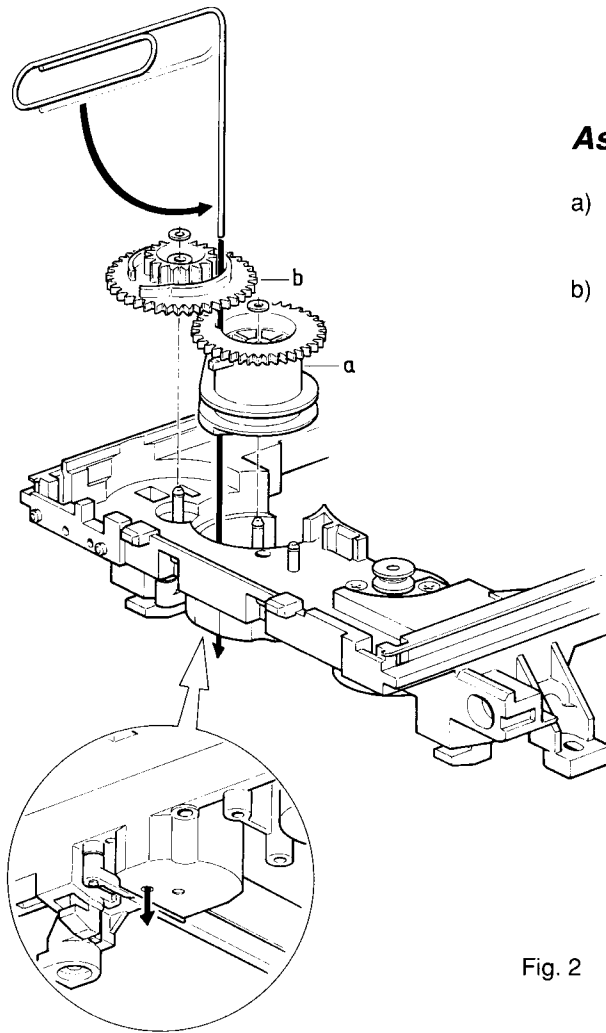

Fig. 1



Assembly of gear

- a) Use a pin (e.g. a paperclip) to align the cam wheel (a) and the gear wheel (b) together. See Fig. 2.
- b) Fix the wheels with the small plastic washers.

Fig. 2

- c) Mount idle wheel2 (c) and idle wheel1 (d) in any position. See Fig. 3.
- d) Fix the idle wheel1 with the small plastic washer.
- e) Mount the driving belt.

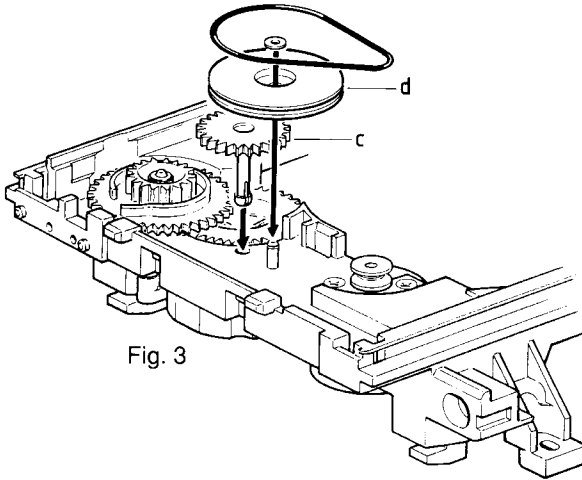

Fig. 3

- f) Mount the pinion guiding assy and the cover as shown in Fig. 4.
- g) Turn the gear wheel (b) counter clockwise to endposition.

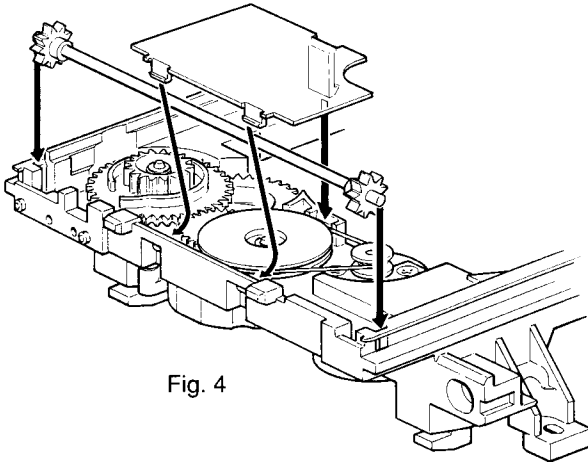

Fig. 4

- h) Mount the CD Mechanism as shown in Fig. 5.
- i) Mount the tray. (Align the tray to the chassis and push it inside)

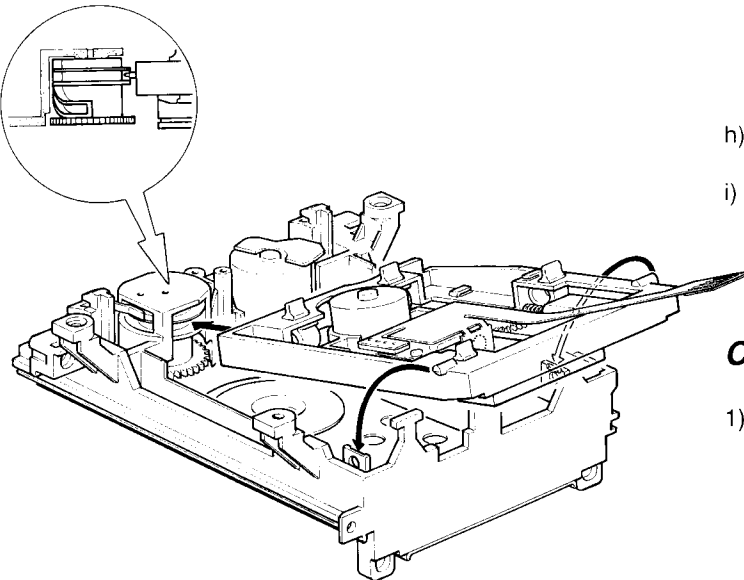

Fig. 5

Check if tray mechanism works correct!

- 1) Turn the gear wheel (b) clockwise to its endposition. (Use a small screwdriver as shown in Fig. 1 point 1)

The tray has to move to inner position first and than the CD Mechanism has to move to its upper position.

- 2) Turn the gear wheel (b) counter clockwise to its endposition.

The CD Mechanism has to move to its lower position first and than the tray has to move to outside.

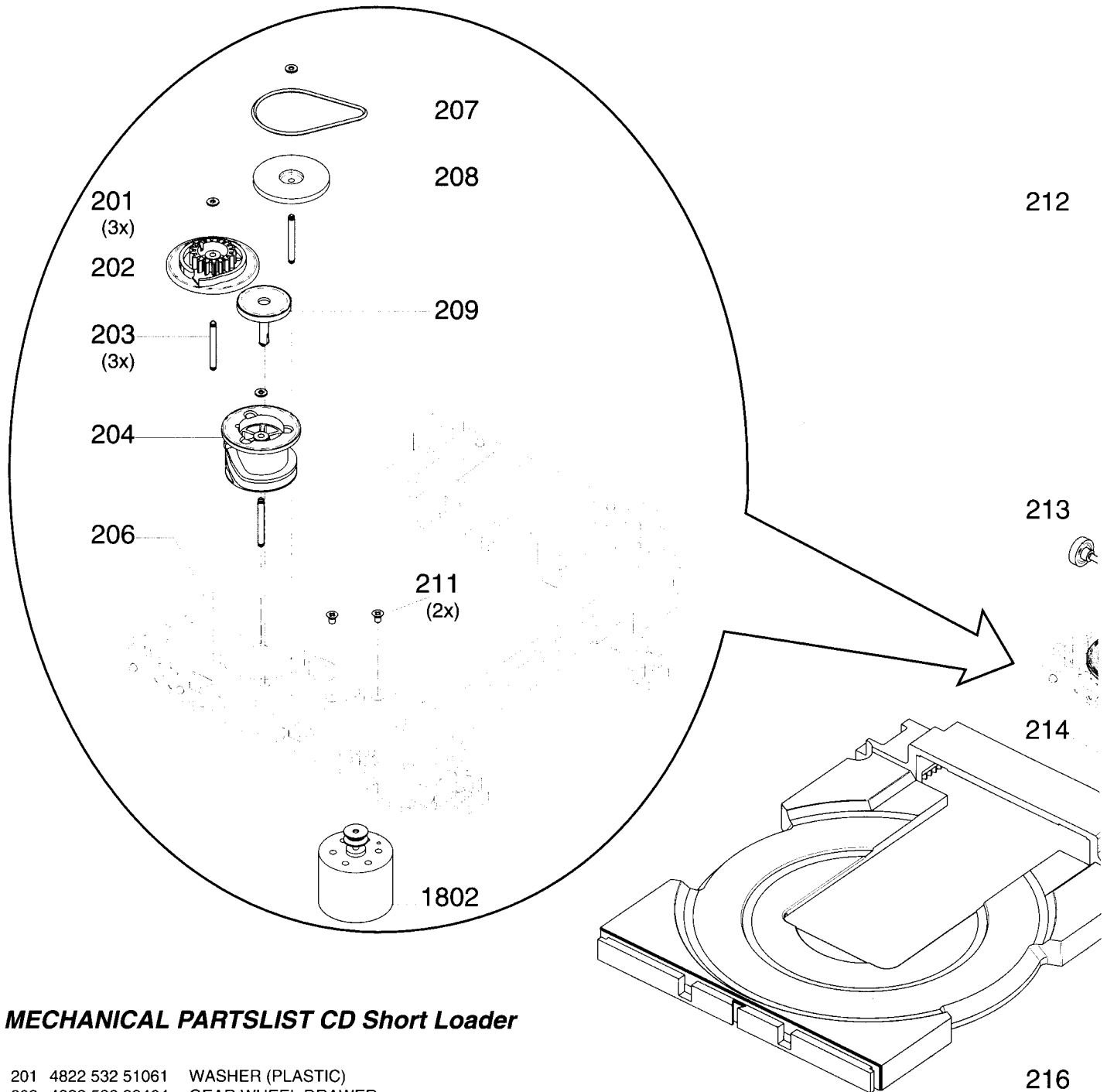
Exploded view CD Short Lc**MECHANICAL PARTSLIST CD Short Loader**

201	4822 532 51061	WASHER (PLASTIC)
202	4822 522 33464	GEAR WHEEL DRAWER
203	4822 535 93466	SPINDLE
204	4822 522 33465	CAM WHEEL
206	4822 464 51031	CHASSIS
207	4822 358 31301	DRIVING BELT
208	4822 528 70851	IDLE WHEEL 1
209	4822 528 70852	IDLE WHEEL 2
211	4822 502 12162	SCREW M2 X 3 (MOTOR)
212	4822 402 61412	CLAMPER ASSY
213	4822 532 52573	PINION GUIDING ASSY
214	4822 402 50312	LEVER SWITCH
216	4822 444 40727	DRAWER
217	4822 502 13886	SCREW PLASTITE 2X6
218	4822 535 93486	PIN FRAME
219	4822 325 50215	SUSPENSION
221	4822 464 51032	FRAME
1800	4822 691 30278	CDM 12.1 ASSY
1802	4822 361 21708	MOTOR ASSY
	4822 502 30735	SCREW 3 X 6 PLASTITE

ader

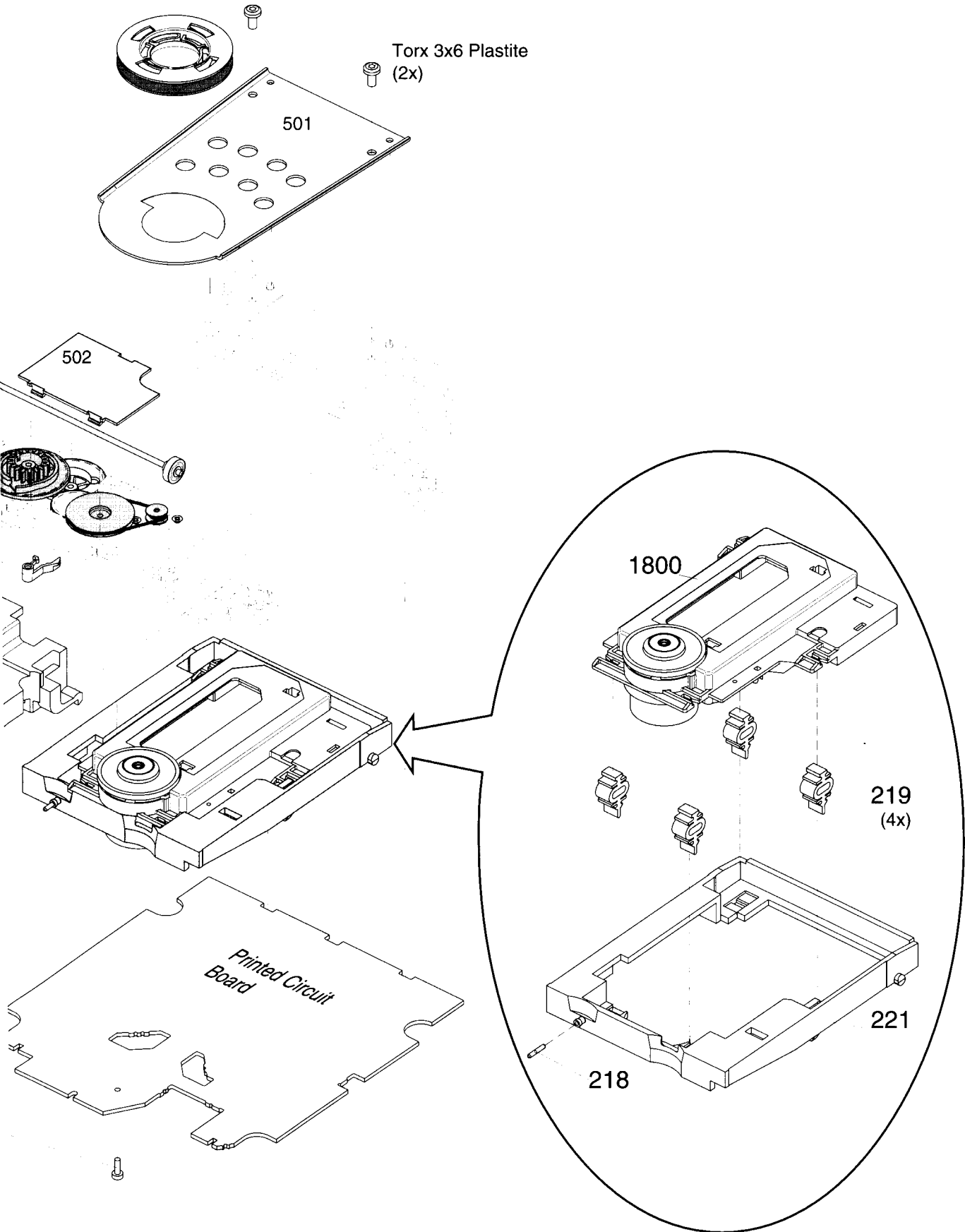

Fault Finding Tree CD

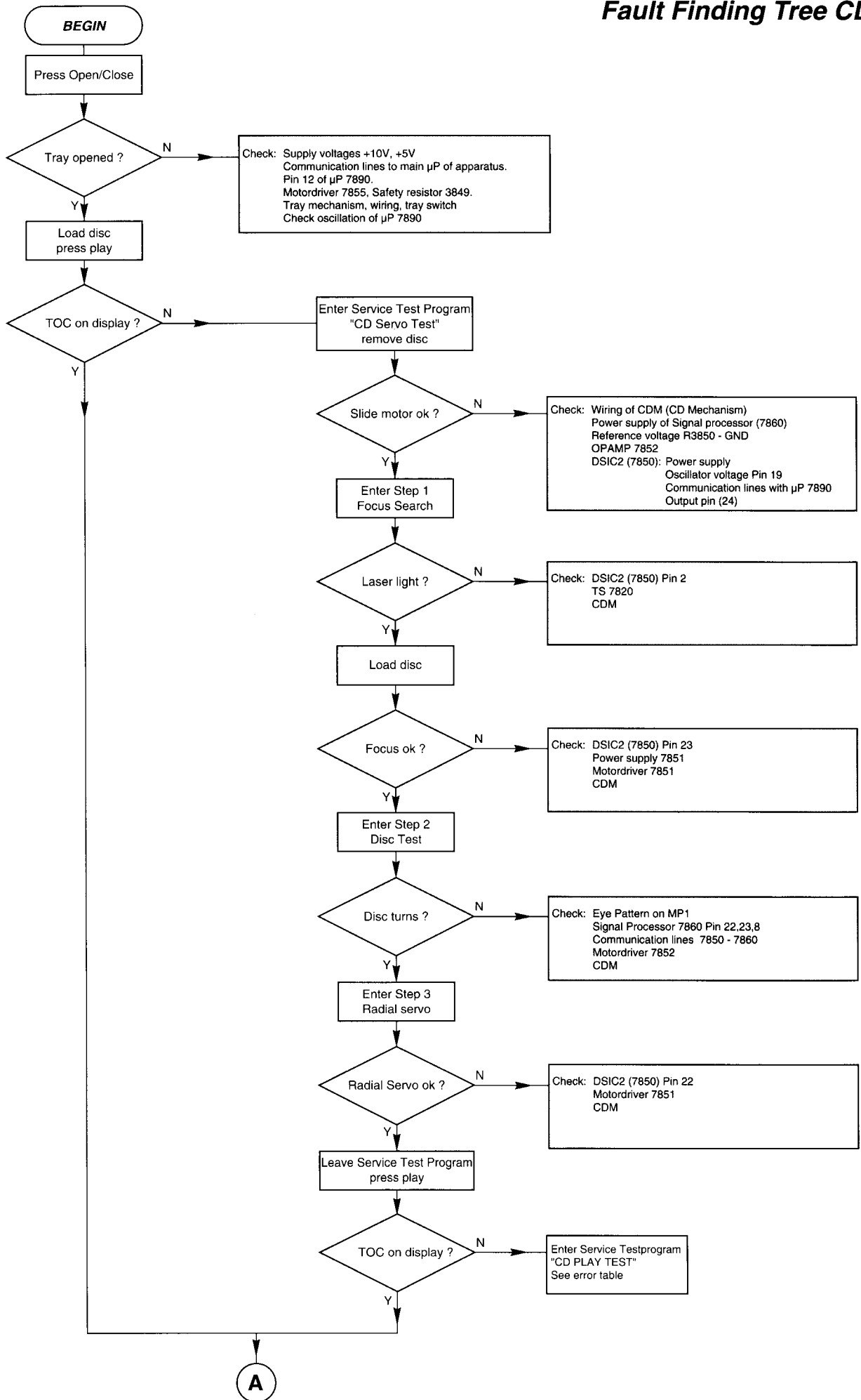

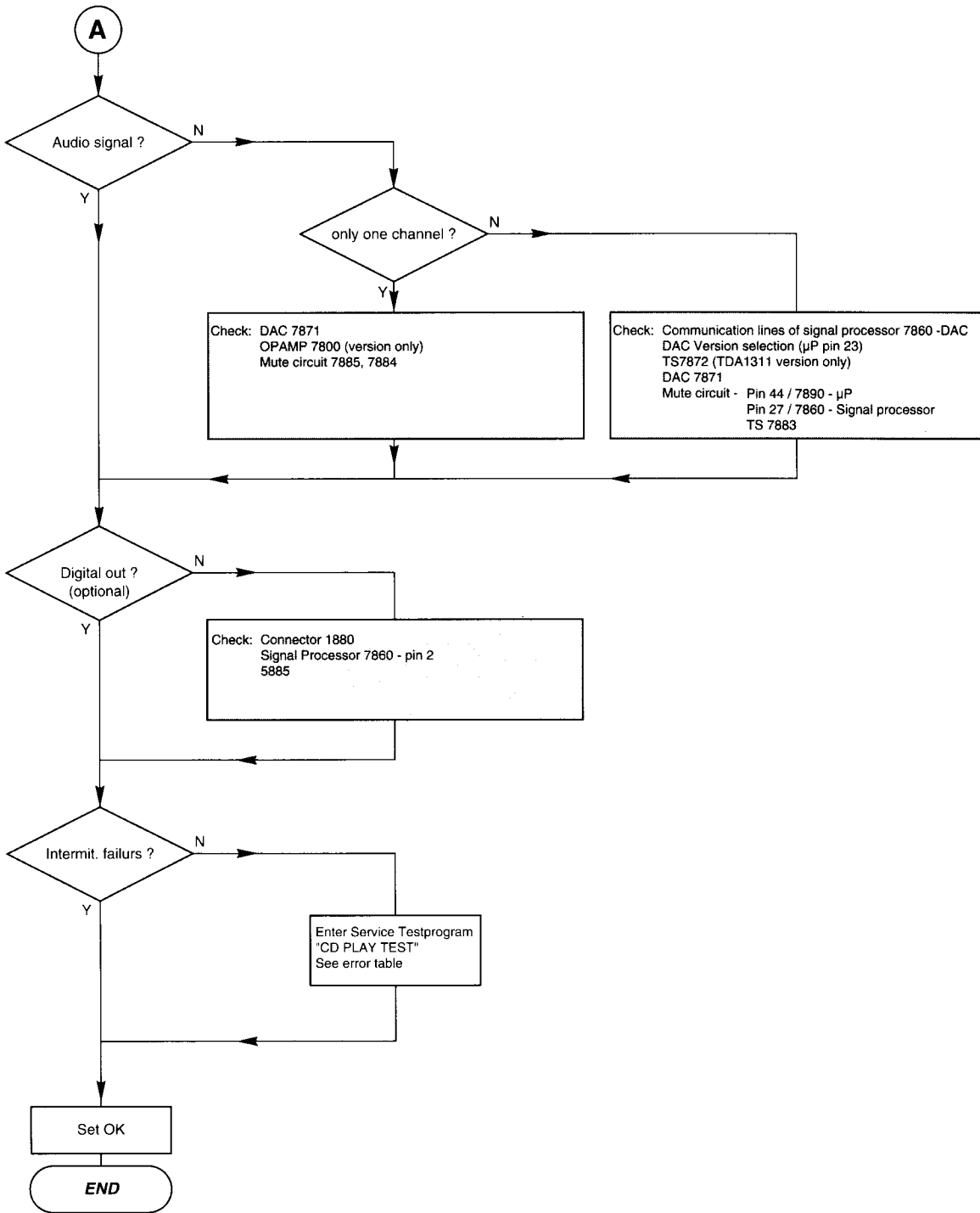

Abbreviations CD

DSIC2

Pin	Name	Direction	Description
1	RESET	μ P -> DSIC2	Reset input (Low level is active)
2	Laser On/Off	DSIC2 -> Laser switch	Switches Laser on/off (High level is active)
3	Gnd	Gnd	Ground (Analogue part)
4	VRH	not connected	Reference input for A/D converter
5	D1	Diode array -> DSIC2	Unipolar current input (Central diode signal input)
6	D2	Diode array -> DSIC2	Unipolar current input (Central diode signal input)
7	D3	Diode array -> DSIC2	Unipolar current input (Central diode signal input)
8	Vref	Gnd	Reference input for A/D converter
9	D4	Diode array -> DSIC2	Unipolar current input (Central diode signal input)
10	R1	Diode array -> DSIC2	Unipolar current input (Satellite diode signal input)
11	R2	Diode array -> DSIC2	Unipolar current input (Satellite diode signal input)
12	VDD		Supply for DSIC2 (Analogue part)
13			
14	TS1	Gnd	Test input 1
15	TS2	Gnd	Test input 2
16	OTD	DSIC2 -> Signal Processor	Off Track Detection (Low level is active)
17	CLO	not connected	Clock output
18	XTLO		Oscillator output pin
19	XTLI		Oscillator input pin
20	VDD		+Supply for DSIC2 (Digital part)
21	Gnd		Ground (Digital part)
22	Track	DSIC2 -> Servo Driver	Radial actuator output
23	Focus	DSIC2 -> Servo Driver	Focus actuator output
24	Slide	DSIC2 -> Motor Driver	Slide motor output
25	SILD	μ P -> DSIC2	Serial Interface Load
26	SICL	μ P -> DSIC2	Serial Interface Clock
27	SIDA	μ P <-> DSIC2	Serial Interface Data
28	VDD		+Supply for DSIC2 (Digital part)

SIGNAL PROCESSOR

Pin	Name	Direction	Description
1	CL11	not connected	11.2896MHz clock output (3-state)
2	DOMB	signal processor -> Digital out	digital bi-phase mark output (3-state)
3	V1	DSIC2 -> signal processor	versatile input pin of signal processor
4	V2	not connected	versatile input pin of signal processor
5	Test2	GND	test input of signal processor
6	Test1	GND	test input of signal processor
7	ISLICE	signal processor -> signal processor	current feedback from internal data slicer
8	HFIN	HF Pre-amp -> signal processor	comparator signal input
9	HFREF	HF Pre-amp -> signal processor	comparator signal input
10	IREF	-> signal processor	reference current pin (nom. VDD/2)
11	VDDA		+supply (analog) of signal processor
12	VSSA		-supply (analog) of signal processor
13	CRIN	X-tal -> signal processor	crystal/resonator input of signal processor
14	CROUT	signal processor -> X-Tal	crystal/resonator output of signal processor
15	VDD1		+supply for I/O-buffers of signal processor
16	VSS1		-supply for I/O-buffers of signal processor
17	CL16	not connected	16.9344MHz clock output of signal processor
18	MISC	not connected	general purpose DAC output (3-state)
19	DATA	signal processor -> DAC	serial data output of signal processor (3-state)
20	WCLK	signal processor -> DAC	word clock output of signal processor (3-state)
21	SCLK	signal processor -> DAC	serial bit clock output of signal processor (3-state)
22	MOTOR1	signal processor -> Disc motor driver	motor output1 of signal processor; versatile (3-state)
23	MOTOR2	signal processor -> Disc motor driver	motor output 2 of signal processor; versatile (3-state)
24	V5	not connected	versatile output pin of signal processor
25	V4	not connected	versatile output pin of signal processor
26	V3	not connected	versatile output pin of signal processor (open drain)
27	KILL	signal processor -> Mute circuit	kill output; programmable (open drain)
28	PORE	μ P -> signal processor	power-on reset enable input (active low)
29	CLA	not connected	4.2336MHz microprocessor clock output
30	DA	μ P <-> signal processor	interface data I/O-line
31	CL	μ P -> signal processor	interface clock input line
32	RAB	μ P -> signal processor	interface R/W and acknowledge input
33	CFLG	signal processor ->	correction flag output (open drain)
34-42	not used		
43	VSS2		digital supply for internal logic of signal processor
44	VDD2		digital supply for internal logic of signal processor

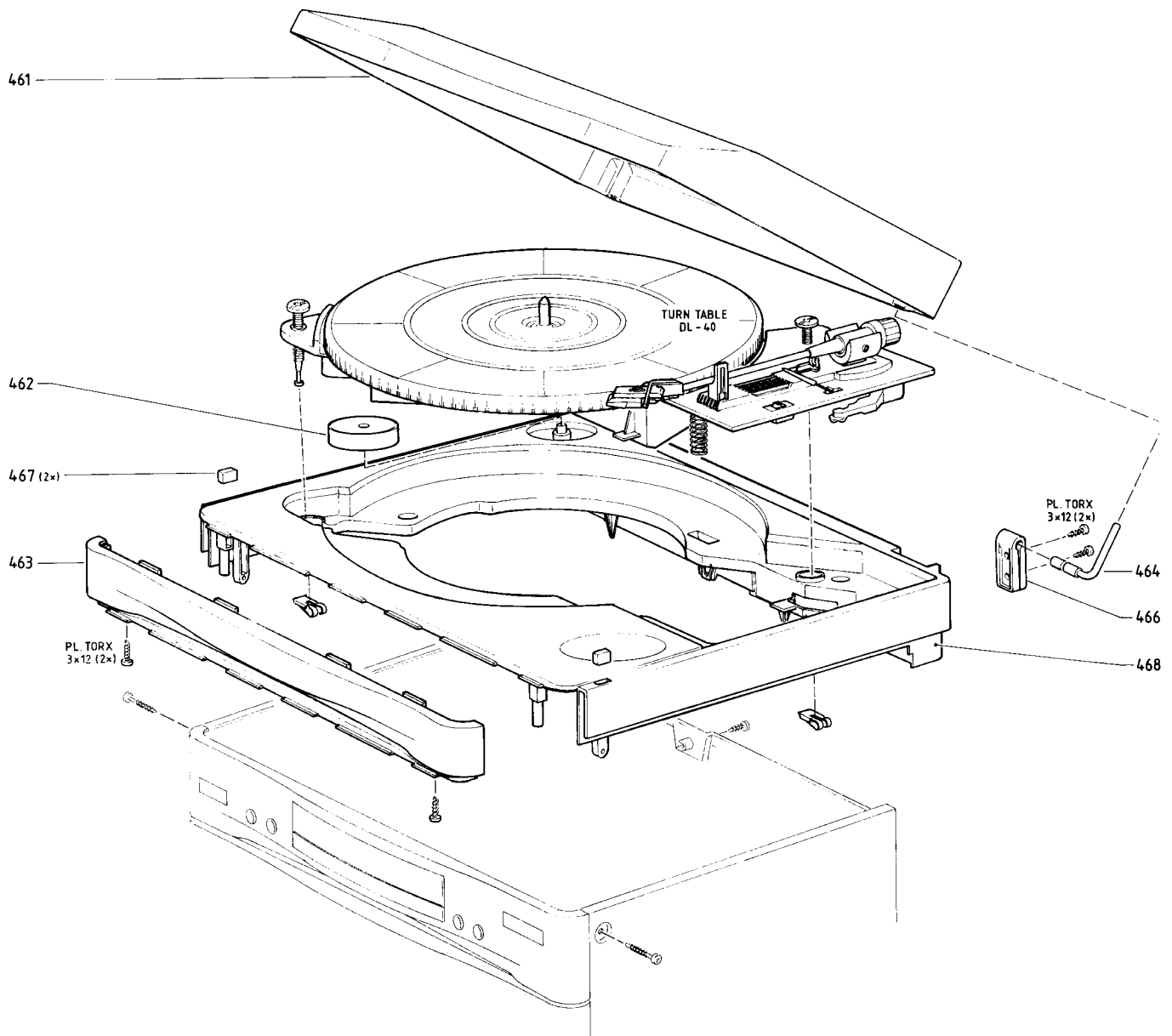
Exploded view Record Player**MECHANICAL PARTS**

461	4822 462 71935	DUST COVER
462	4822 466 92642	ADAPTOR
463	4822 444 40662	FRONT RECORD PLAYER
464	4822 535 93499	PIN (HINGE)
466	4822 417 10631	CLAMPING BLOCK

467 4822 462 41656 RUBBER PAD

468 not a sparepart

For detailed info of record player see Annex (Service Manual DL40)

Exploded view of Set I

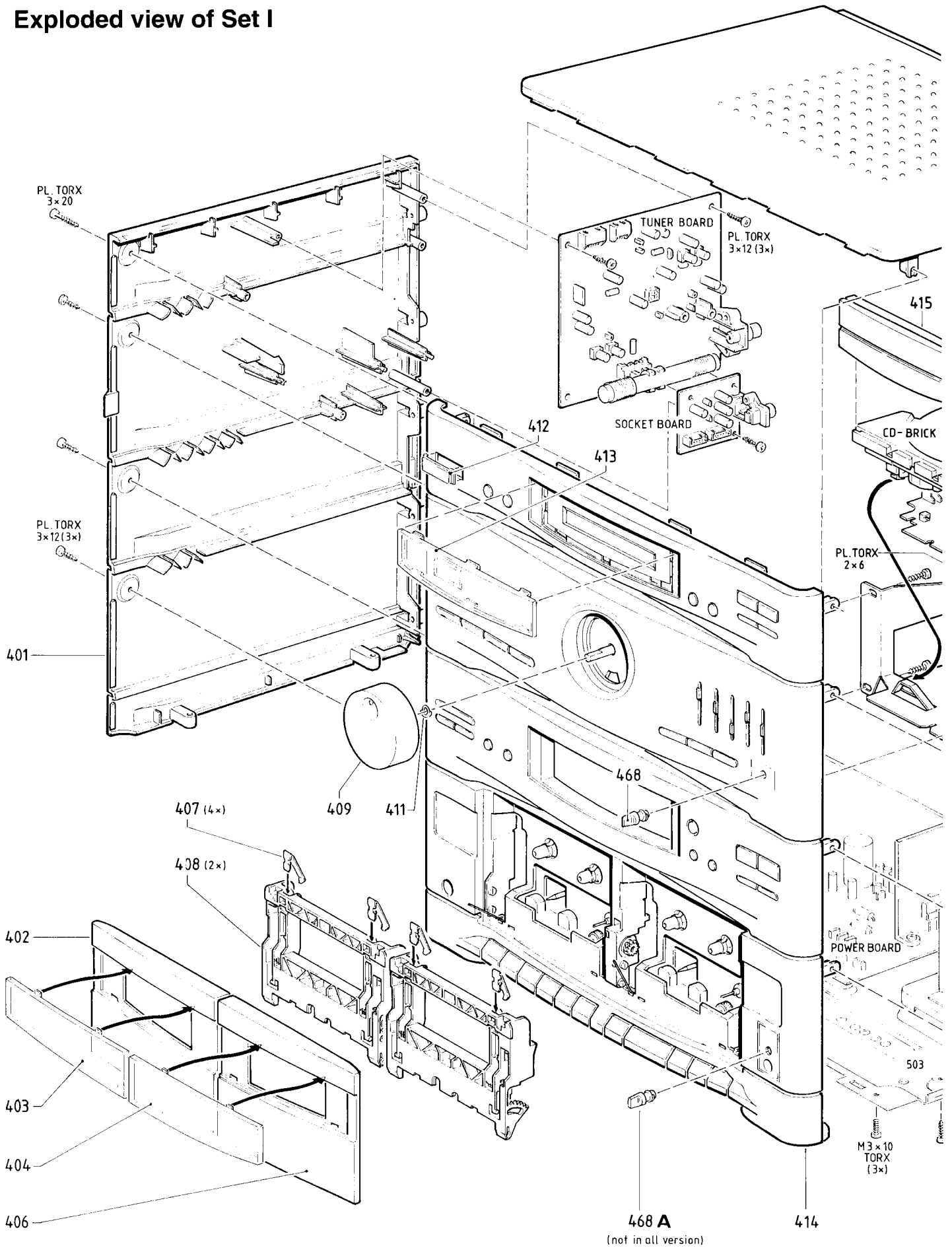

MECHANICAL PARTS

- 401 4822 426 30153 SIDE LEFT
- 402 4822 443 63936 CASS. DOOR A-DECK
- 403 4822 450 62087 WINDOW A-DECK
- 404 4822 450 62088 WINDOW B-DECK
- 406 4822 443 63935 CASS. DOOR B-DECK

- 407 4822 492 63927 SPRING,CASS.PRESS
- 408 4822 443 63037 DOOR,CASSETTE
- 409 4822 413 41792 KNOB VOLUME
- 411 4822 492 51374 SPRING KNOB CLAMP
- 412 4822 381 11418 IR WINDOW

- 413 4822 450 62093 WINDOW PRINTED
- 414 4822 426 51663 FRONT AS540
- 414 4822 426 51664 FRONT AS545
- 415 4822 444 40743 FRONT CD TRAY
- 416 4822 426 60639 COVER

- 417 4822 426 20241 BACK PLATE
- 418 4822 426 30152 SIDE RIGHT

MISCELLANEOUS

- 4822 445 10366 LS BOX
- 4822 303 50063 FM AERIAL
- 4822 218 10513 IR REMOTE CONTROL
- 4822 321 10831 MAINS CORD /21
- 4822 321 10954 MAINS CORD /30

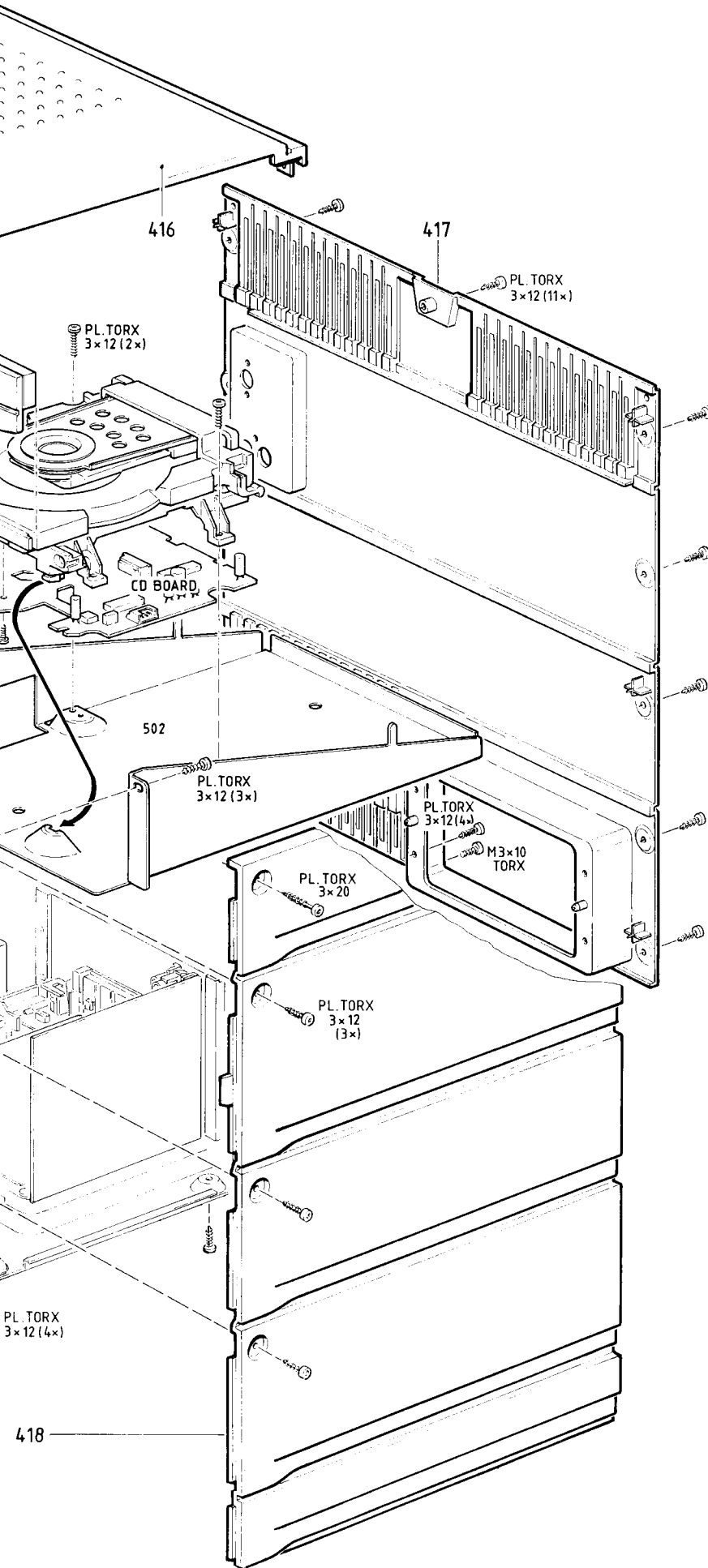

Exploded view of Set II

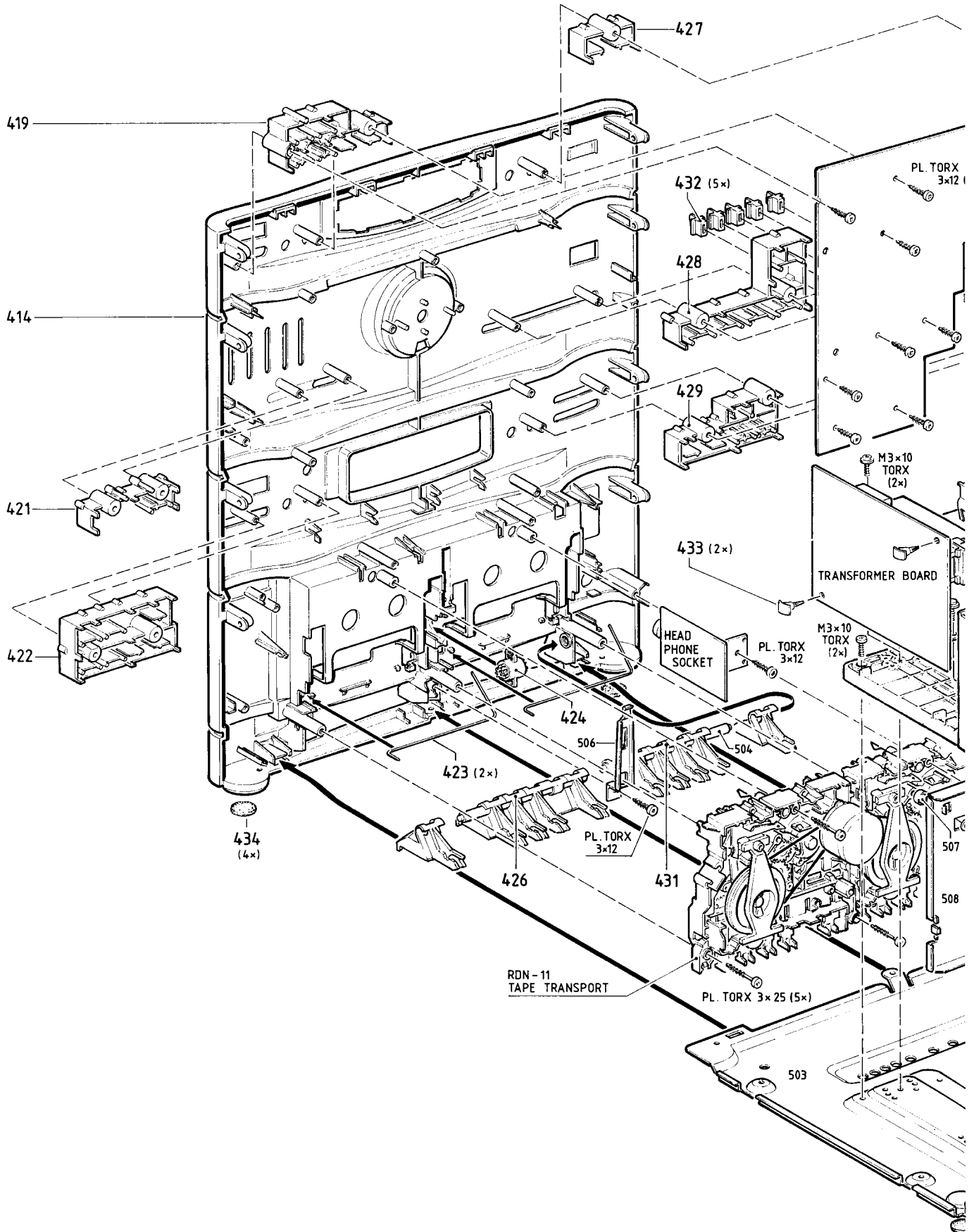

MECHANICAL PARTS

414	4822 426 51663	FRONT AS540
414	4822 426 51664	FRONT AS545
419	4822 410 62618	KNOB PRSET UP/DOWN
421	4822 410 62683	KNOB HSD, FE/CHROME
422	4822 410 62626	KNOB CD RIGHT
423	4822 492 42595	SPRING CASS. COMPART
424	4822 529 10278	DAMPER
426	4822 410 62621	BUTTON SET
427	4822 410 62623	KNOB AUTOPROGRAM
428	4822 410 62617	KNOB SELECTOR+POWER
429	4822 410 62724	KNOB CD LEFT
431	4822 410 62619	BUTTON SET
432	4822 411 61929	KNOB EQUALIZER
433	4822 466 93148	SPACER
434	4822 462 40683	FOOT RUBBER
468	4822 413 31758	KNOB BALANCE
468A	4822 410 62622	KNOB MICRO-MIX

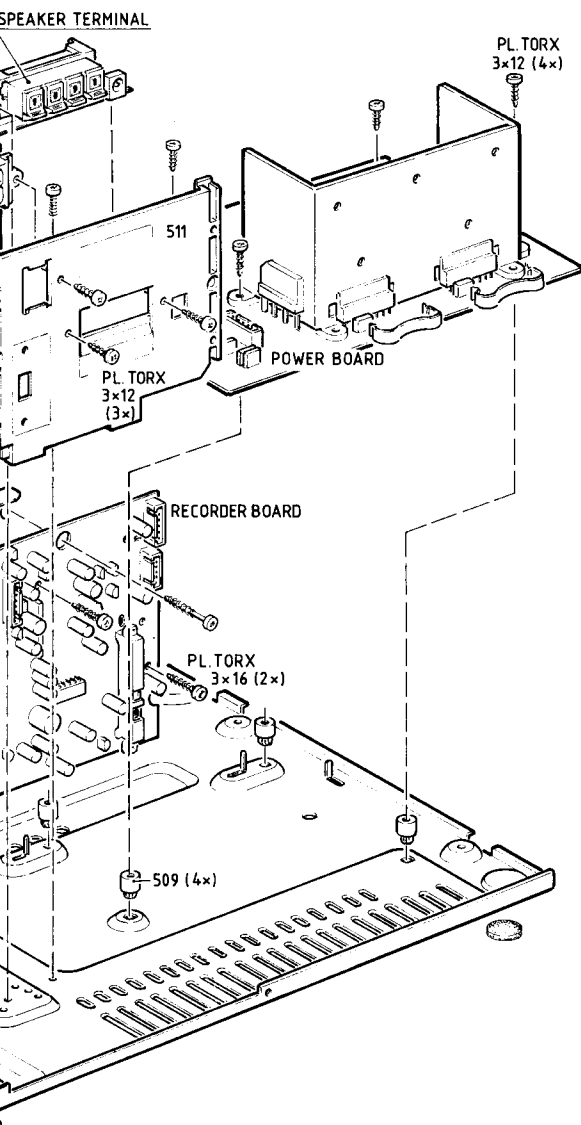
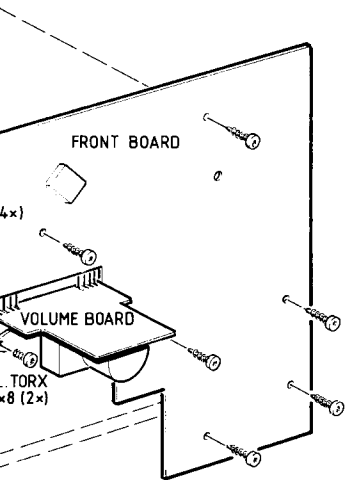

MISCELLANEOUS

4822 445 10366	LS BOX
4822 303 50063	FM AERIAL
4822 218 10513	IR REMOTE CONTROL
4822 321 10831	MAINS CORD /21
4822 321 10954	MAINS CORD /30

CD PART**MISCELLANEOUS**

 1810 4822 276 13503 SWITCH
DIODES

 6857 4822 130 30621 1N4148
 6881 4822 130 31981 BZX79-C3V9
 6883 4822 130 31981 BZX79-C3V9
TRANSISTORS

 7820 4822 130 41344 BC337-40
 7856 5322 130 60123 BC807-40 (CHIP)
 7872 5322 130 42136 BC848C (CHIP)
 7881 5322 130 41983 BC858B (CHIP)
 7883 4822 130 44197 BC558B

 7884 4822 130 41344 BC337-40
 7885 4822 130 41344 BC337-40
INTEGRATED CIRCUITS

 7001 4822 209 80891 MC7805CT
 7800 5322 209 11517 PC74HCU04T
 7850 4822 209 31064 TDA1301T/N1
 7851 4822 209 32852 TDA7073A/N2
 7852 4822 209 32852 TDA7073A/N2

 7855 4822 209 31519 TDA7072A
 7860 4822 209 33339 SAA7345GP/M5
 7871 4822 209 32196 TDA1311AT/N2
 7886 4822 272 10371 7805 (Voltage regulator)
 7890 4822 209 33337 MC68HC05C8FB
COILS

 5860 4822 543 00376 QUARTZ 16,934 MHz
 5890 4822 242 72527 CERAMIC RES. 4.0 MHz
RESISTORS

 3760 4822 116 52296 6k8 5% 0,5W
 3761 4822 116 52283 4k7 5% 0,5W
 3801 4822 116 52224 470R 5% 0,5W
 3815 4822 050 11002 1k 5% 0,2W
 3818 4822 116 52233 10k 5% 0,5W

 3820 4822 050 11002 1k 5% 0,2W
 3825 4822 116 52233 10k 5% 0,5W
 3826 4822 116 52233 10k 5% 0,5W
 3827 4822 116 52233 10k 5% 0,5W
 3828 4822 116 52233 10k 5% 0,5W

 3829 4822 116 52233 10k 5% 0,5W
 3830 4822 116 52233 10k 5% 0,5W
 3832 4822 116 52175 100R 5% 0,5W
 3833 4822 116 52233 10k 5% 0,5W
 3835 4822 116 52264 27k 5% 0,5W

 3836 4822 116 52207 1k2 5% 0,5W
 3837 4822 116 52296 6k8 5% 0,5W
 3838 4822 116 52257 22k 5% 0,5W
 3839 4822 116 52207 1k2 5% 0,5W
 3840 4822 116 52296 6k8 5% 0,5W
RESISTORS

 3841 4822 116 52297 68k 5% 0,5W
 3843 4822 116 52277 39k 5% 0,16W
 3844 4822 050 11002 1k 5% 0,2W
 3845 4822 116 52277 39k 5% 0,16W
 3846 4822 050 11002 1k 5% 0,2W

 3847 4822 116 40227 4R7 PTC
 3848 4822 050 11002 1k 5% 0,2W
 3849 4822 052 10338 3R3 NFR25
 3850 4822 050 11002 1k 5% 0,2W
 3851 4822 116 52264 27k 5% 0,5W

 3852 4822 050 11002 1k 5% 0,2W
 3853 4822 116 52296 6k8 5% 0,5W
 3857 4822 116 52215 220R 5% 0,16W
 3858 4822 116 52215 220R 5% 0,16W
 3860 4822 116 52175 100R 5% 0,5W

 3871 4822 116 52186 22R 5% 0,5W
 3876 4822 116 52284 47k 5% 0,5W
 3877 4822 116 52284 47k 5% 0,5W
 3880 4822 050 11002 1k 5% 0,2W
 3881 4822 050 11002 1k 5% 0,2W

 3886 4822 116 52226 560R 5% 0,5W
 3889 4822 116 52233 10k 5% 0,5W
 3891 4822 116 52186 22R 5% 0,5W
CHIP RESISTORS

 3750 4822 051 20154 150k 5% 0,1W
 3751 4822 051 20331 330R 5% 0,1W
 3752 4822 051 20221 220R 5% 0,1W
 3754 4822 051 20105 1M 5% 0,1W
 3755 4822 117 10833 10k 1% 0,1W

 3762 4822 051 20221 220R 5% 0,1W
 3763 4822 051 20221 220R 5% 0,1W
 3764 4822 051 20221 220R 5% 0,1W
 3785 4822 117 10833 10k 1% 0,1W
 3790 4822 117 10833 10k 1% 0,1W

 3791 4822 117 10833 10k 1% 0,1W
 3792 4822 117 10833 10k 1% 0,1W
 3793 4822 117 10833 10k 1% 0,1W
 3795 4822 117 10833 10k 1% 0,1W
 3802 4822 051 10102 1k 2% 0,25W

 3803 4822 051 20335 3M3 5% 0,1W
 3804 4822 051 20682 6k8 5% 0,1W
 3805 4822 051 20223 22k 5% 0,1W
 3806 4822 117 10833 10k 1% 0,1W
 3807 4822 117 10833 10k 1% 0,1W

 3808 4822 117 10834 47k 1% 0,1W
 3809 4822 051 20332 3k3 5% 0,1W
 3810 4822 051 20332 3k3 5% 0,1W
 3811 4822 051 20223 22k 5% 0,1W
 3812 4822 051 20332 3k3 5% 0,1W

 3813 4822 051 20332 3k3 5% 0,1W
 3814 4822 051 20332 3k3 5% 0,1W
 3821 4822 051 20124 120k 5% 0,1W
 3822 4822 051 20563 56k 5% 0,1W
 3823 4822 051 20331 330R 5% 0,1W

CHIP RESISTORS

3824	4822 051 20124	120k	5%	0,1W
3831	4822 051 20223	22k	5%	0,1W
3834	4822 051 20229	22R	5%	0,1W
3842	4822 051 20182	1k8	5%	0,1W
3854	4822 117 10833	10k	1%	0,1W
3855	4822 051 20224	220k	5%	0,1W
3856	4822 051 20223	22k	5%	0,1W
3862	4822 051 20105	1M	5%	0,1W
3863	4822 051 10102	1k	2%	0,25W
3864	4822 051 10102	1k	2%	0,25W
3865	4822 051 10102	1k	2%	0,25W
3866	4822 051 20331	330R	5%	0,1W
3867	4822 051 20472	4k7	5%	0,1W
3885	4822 051 20222	2k2	2%	0,25W
3887	4822 051 20473	47k	5%	0,1W
3890	4822 051 10102	1k	2%	0,25W
3892	4822 117 10833	10k	1%	0,1W
3893	4822 117 10833	10k	1%	0,1W
3894	4822 117 10833	10k	1%	0,1W
3895	4822 117 10833	10k	1%	0,1W
3896	4822 117 10833	10k	1%	0,1W
3899	4822 117 10833	10k	1%	0,1W
4801	4822 051 10008	CHIP JUMPER 1206		
4802	4822 051 10008	CHIP JUMPER 1206		
4805	4822 051 10008	CHIP JUMPER 1206		
4806	4822 051 10008	CHIP JUMPER 1206		
4808	4822 051 10008	CHIP JUMPER 1206		
4809	4822 051 10008	CHIP JUMPER 1206		
4810	4822 051 10008	CHIP JUMPER 1206		
4811	4822 051 10008	CHIP JUMPER 1206		
4812	4822 051 10008	CHIP JUMPER 1206		
4813	4822 051 10008	CHIP JUMPER 1206		
4814	4822 051 10008	CHIP JUMPER 1206		
4815	4822 051 10008	CHIP JUMPER 1206		
4816	4822 051 10008	CHIP JUMPER 1206		
4820	4822 051 10008	CHIP JUMPER 1206		
4850	4822 051 10008	CHIP JUMPER 1206		
4851	4822 051 10008	CHIP JUMPER 1206		

CAPACITORS

2752	5322 122 32531	100pF	5%	50V
2753	5322 122 32531	100pF	5%	50V
2762	5322 122 32658	22pF	5%	50V
2763	5322 122 32658	22pF	5%	50V
2764	5322 122 32658	22pF	5%	50V
2769	4822 124 80115	4,7μF	20%	25V
2770	4822 124 80115	4,7μF	20%	25V
2814	4822 126 12339	2,2nF	10%	16V
2818	4822 124 80483	47μF	20%	6,3V
2831	4822 124 80483	47μF	20%	6,3V
2833	4822 124 80483	47μF	20%	6,3V
2836	4822 126 13098	5,6nF	20%	16V
2837	4822 122 10459	560pF	10%	50V
2839	4822 121 51387	10nF	20%	16V
2840	4822 122 10576	1,8nF	10%	16V
2843	5322 124 41948	0,47μF	20%	50V
2847	5322 124 41942	33μF	20%	25V
2848	4822 124 80483	47μF	20%	6,3V
2849	4822 124 40433	47μF	20%	25V
2850	4822 124 80115	4,7μF	20%	25V

CAPACITORS

2851	4822 121 51387	10nF	20%	16V
2853	5322 121 42386	100nF	5%	63V
2856	5322 121 42661	330nF	5%	63V
2860	4822 124 40177	47μF	20%	10V
2864	4822 124 42433	330μF	20%	6,3V
2866	4822 124 42433	330μF	20%	6,3V
2892	4822 124 11423	4,7μF	20%	

CHIP CAPACITORS

2802	4822 122 33064	330nF	20%	25V
2803	4822 122 33515	82pF	5%	50V
2804	4822 122 33515	82pF	5%	50V
2805	5322 122 33538	150pF	5%	63V
2806	5322 122 31946	27pF	5%	50V
2807	5322 122 32452	47pF	5%	50V
2808	5322 122 32452	47pF	5%	50V
2809	5322 122 32452	47pF	5%	50V
2810	5322 122 32481	15pF	5%	50V
2811	5322 122 33538	150pF	5%	63V
2820	5322 116 80853	560pF	5%	63V
2821	4822 126 10326	180pF	5%	
2822	5322 122 31863	330pF	5%	50V
2823	5322 122 31865	1,5nF	10%	63V
2824	4822 126 10326	180pF	5%	
2825	4822 122 33575	220pF	5%	50V
2826	4822 122 33575	220pF	5%	50V
2827	4822 122 33575	220pF	5%	50V
2828	4822 122 33575	220pF	5%	50V
2829	4822 122 33575	220pF	5%	50V
2830	4822 122 33575	220pF	5%	50V
2834	5322 122 32654	22nF	10%	63V
2838	4822 122 33496	100nF	10%	63V
2852	4822 122 33496	100nF	10%	63V
2854	5322 122 32531	100pF	5%	50V
2857	5322 122 32452	47pF	5%	50V
2858	5322 122 32654	22nF	10%	63V
2859	4822 122 33496	100nF	10%	63V
2861	5322 122 32658	22pF	20%	50V
2862	5322 122 32661	56pF	20%	50V
2867	4822 122 33496	100nF	10%	63V
2876	5322 122 34123	1nF	10%	50V
2877	5322 122 34123	1nF	10%	50V
2878	5322 122 32531	100pF	5%	50V
2879	5322 122 32531	100pF	5%	50V
2881	4822 122 33496	100nF	10%	63V
2883	4822 122 33064	330nF	20%	25V
2891	4822 122 33496	100nF	10%	63V
2893	5322 122 32531	100pF	5%	50V
2894	5322 122 32531	100pF	5%	50V
2895	5322 122 32531	100pF	5%	50V
2897	5322 122 32838	82nF	5%	50V

ECO4 VA Tuner**MISCELLANEOUS**

1101	4822 267 10283	SOCKET COAX IEC 75R
1101	4822 265 20598	F-CONNECT. COAX 75R

DIODES

6105	4822 130 83075	HN1V02H
6109	4822 130 82833	1SV228
6121	4822 130 30621	1N4148
6122	4822 130 30621	1N4148
6123	4822 130 30621	1N4148
6124	4822 130 82833	1SV228
6140	4822 130 30621	1N4148
6154	4822 130 30621	1N4148
6174	4822 130 34233	BZX79-B5V1

TRANSISTORS

7102	5322 130 42136	BC848C(CHIP)
7104	5322 130 42136	BC848C(CHIP)
7105	4822 130 60093	2SA838B
7120	4822 130 60163	2SC1047
7121	5322 130 42136	BC848C(CHIP)
7123	5322 130 42136	BC848C(CHIP)
7128	5322 130 42136	BC848C(CHIP)
7168	5322 130 41983	BC858B(CHIP)
7170	5322 130 42136	BC848C(CHIP)
7171	5322 130 42136	BC848C(CHIP)
7179	5322 130 42136	BC848C(CHIP)

INTEGRATED CIRCUITS

7140	4822 209 32701	TEA5712T/N2 (RF IC)
7172	5322 209 11517	PC74HCU04T (or MM74HCU04M)
7173	4822 209 31998	LC7218M SYNTHESIZER

COILS

5105	4822 158 60641	Ferrite ant.,MW/LW
5106	4822 158 60642	Ferrite ant.,MW
5109	4822 156 30947	RF COIL 1,5 TURNS
5120	4822 156 30947	RF COIL 1,5 TURNS
5122	4822 157 60517	110µH OSC. COIL LW
5123	4822 157 60517	110µH OSC. COIL MW
5125	4822 157 61898	0,47µH only for /21
5140	4822 158 60511	AM-IF FILTER 450kHz
5142	4822 157 70302	AM-IF FILTER 450kHz
5143	4822 242 70665	CER. FILTER 10,7MHZ
5144	4822 242 70665	CER. FILTER 10,7MHZ
5145	4822 242 81362	CER. DISCRIMINATOR
5170	4822 242 72976	CER. RESONATOR 7,2MHZ

RESISTORS

3112	4822 116 52176	10R	5%	0,5W
3119	4822 116 52224	470R	5%	0,5W
3120	4822 116 52289	5k6	5%	0,16W
3124	4822 116 52256	2k2	5%	0,16W
3132	4822 116 52283	4k7	5%	0,5W
3141	4822 116 52215	220R	5%	0,16W
3148	4822 100 11163	TRIMPOT. 100k lin.		
3151	4822 116 52243	1k5	5%	0,16W
3156	4822 116 52233	10k	5%	0,5W
3162	4822 050 11002	1k	5%	0,2W
3163	4822 050 11002	1k	5%	0,2W
3170	4822 116 52283	4k7	5%	0,5W
3173	4822 116 52244	15k	5%	0,5W
3174	4822 116 52233	10k	5%	0,5W
3177	4822 116 52233	10k	5%	0,5W
3189	4822 116 52249	1k8	5%	0,16W
3190	4822 116 52249	1k8	5%	0,16W
3191	4822 116 52249	1k8	5%	0,16W
3192	4822 116 52249	1k8	5%	0,16W
3193	4822 116 52256	2k2	5%	0,16W
3194	4822 116 52219	330R	5%	0,5W
3195	4822 116 52219	330R	5%	0,5W
3197	4822 116 52219	330R	5%	0,5W
3206	4822 116 52215	220R	5%	0,16W

only for /21

CHIP RESISTORS

3106	4822 051 20104	100k	5%	0,1W
3107	4822 051 20222	2k2	5%	0,1W
3108	4822 051 20104	100k	5%	0,1W
3109	4822 051 20222	2k2	5%	0,1W
3116	4822 051 20335	3M3	5%	0,1W
3121	4822 051 20104	100k	5%	0,1W
3122	4822 051 20471	470R	5%	0,1W
3123	4822 051 20223	22k	5%	0,1W
3125	4822 051 20472	4k7	5%	0,1W
3128	4822 117 10833	10k	1%	0,1W
3129	4822 051 20472	4k7	5%	0,1W
3142	4822 051 20222	2k2	5%	0,1W
3144	4822 117 10833	10k	1%	0,1W
3147	4822 051 20184	180k	5%	0,1W
3149	4822 051 20563	56k	5%	0,1W
3157	4822 051 20273	27k	5%	0,1W
3158	4822 051 20189	18R	5%	0,1W
3159	4822 051 20563	56k	5%	0,1W
3167	4822 051 20008	CHIP JUMPER 0805		
3171	4822 051 20101	100R	5%	0,1W
3172	4822 051 20472	4k7	5%	0,1W
3175	4822 051 20104	100k	5%	0,1W
3176	4822 051 20101	100R	5%	0,1W
3183	4822 051 20223	22k	5%	0,1W
3184	4822 051 20223	22k	5%	0,1W
3186	4822 051 20104	100k	5%	0,1W
3188	4822 051 10102	1k	2%	0,25W
3211	4822 051 10008	CHIP JUMPER 1206		
3212	4822 051 10008	CHIP JUMPER 1206		
3213	4822 051 10008	CHIP JUMPER 1206		

CHIP RESISTORS

3222	4822 051 20008	CHIP JUMPER 0805
3223	4822 051 20008	CHIP JUMPER 0805
3224	4822 051 20008	CHIP JUMPER 0805
3226	4822 051 20008	CHIP JUMPER 0805
3228	4822 051 10008	CHIP JUMPER 1206
3229	4822 051 20008	CHIP JUMPER 0805
3231	4822 051 20008	CHIP JUMPER 0805
3233	4822 051 20008	CHIP JUMPER 0805
3235	4822 051 20008	CHIP JUMPER 0805
3237	4822 051 10008	CHIP JUMPER 1206
3238	4822 051 20008	CHIP JUMPER 0805
3240	4822 051 10479	47R
3241	4822 051 20008	CHIP JUMPER 0805
3242	4822 051 10008	CHIP JUMPER 1206
3243	4822 051 20008	CHIP JUMPER 0805
3244	4822 051 20008	CHIP JUMPER 0805
3245	4822 051 20008	CHIP JUMPER 0805
3246	4822 051 10008	CHIP JUMPER 1206
3247	4822 051 10008	CHIP JUMPER 1206
3248	4822 051 10008	CHIP JUMPER 1206

CHIP CAPACITORS

2138	5322 122 32659	33pF	5%	50V
2139	4822 122 33891	3,3nF	10%	63V
2145	4822 122 33496	100nF	10%	63V
2146	5322 122 33063	2,2pF	10%	50V
2147	4822 122 33177	10nF	20%	50V
2154	4822 122 33893	18nF	10%	63V
2154	4822 122 32541	27nF	for US version only	
2155	4822 122 33893	18nF	10%	63V
2155	4822 122 32541	27nF	for US version only	
2167	4822 122 33496	100nF	10%	63V
2169	5322 122 31863	330pF	5%	50V
2171	5322 126 10223	4,7nF	10%	63V
2180	5322 122 31946	27pF	5%	50V
2181	4822 122 32139	12pF	5%	63V
2183	4822 122 33496	100nF	10%	63V
2185	4822 122 33496	100nF	10%	63V
2186	5322 122 34123	1nF	10%	50V

CAPACITORS

2100	4822 122 33195	100pF	10%	50V
2104	4822 122 33195	100pF	10%	50V
2115	4822 125 60101	3-11pF VARIABLE		
2124	4822 121 51387	10nF	20%	16V
2129	4822 121 43705	390pF	1%	160V
2130	4822 125 50355	4,2-20pF VARIABLE		
2134	4822 122 33197	1nF	10%	50V
2135	4822 121 70245	560pF	1%	160V
2141	4822 124 40244	2,2μF	20%	63V
2142	4822 124 40242	1μF	20%	63V
2143	4822 124 40239	0,47μF	20%	63V
2144	4822 124 40239	0,47μF	20%	63V
2150	4822 124 40248	10μF	20%	63V
2151	4822 124 40248	10μF	20%	63V
2160	4822 124 40242	1μF	20%	63V
2161	4822 124 40242	1μF	20%	63V
2170	4822 126 11714	4,7nF	20%	
2172	4822 124 41631	1,5μF	20%	50V
2173	4822 124 40433	47μF	20%	25V
2177	4822 126 12882	100nF		50V
2178	4822 122 33197	1nF	10%	50V
2179	4822 122 33195	100pF	10%	50V
2184	4822 124 41584	100μF	20%	10V

CHIP CAPACITORS

2107	5322 122 34123	1nF	10%	50V
2110	5322 122 32659	33pF	for MW/LW version only	
2110	5322 122 32269	6,8pF	for MW version only	
2112	4822 122 33496	100nF	10%	63V
2114	5322 122 32531	100pF	5%	50V
2120	5322 122 32268	470pF	10%	50V
2121	5322 122 32481	15pF	5%	50V
2122	5322 122 34123	1nF	10%	50V
2123	5322 122 34123	1nF	10%	50V
2133	4822 122 33128	15nF	10%	63V

FRONT BOARD**MISCELLANEOUS**

1408	4822 267 30631	CINCH SOCKET
1410	4822 267 40659	HEADPHONE SOCKET
1416	4822 134 40965	LAMP INC. 12V 150mA
1417	4822 134 40965	LAMP INC. 12V 150mA
1421	4822 276 13114	TACT SWITCH
1422	4822 276 13114	TACT SWITCH
1423	4822 276 13114	TACT SWITCH
1424	4822 276 13114	TACT SWITCH
1425	4822 276 13114	TACT SWITCH
1426	4822 276 13114	TACT SWITCH
1427	4822 276 13114	TACT SWITCH
1428	4822 276 13114	TACT SWITCH
1429	4822 276 13114	TACT SWITCH
1430	4822 276 13114	TACT SWITCH
1431	4822 276 13114	TACT SWITCH
1432	4822 276 13114	TACT SWITCH
1433	4822 276 13114	TACT SWITCH
1434	4822 276 13114	TACT SWITCH
1435	4822 276 13114	TACT SWITCH
1436	4822 276 13114	TACT SWITCH
1437	4822 276 13114	TACT SWITCH
1438	4822 276 13114	TACT SWITCH
1439	4822 276 13114	TACT SWITCH
1440	4822 276 13114	TACT SWITCH
1442	4822 276 13114	TACT SWITCH
1443	4822 276 13114	TACT SWITCH
1444	4822 276 13114	TACT SWITCH
1445	4822 276 13114	TACT SWITCH
1446	4822 276 13114	TACT SWITCH
1447	4822 276 13114	TACT SWITCH
1448	4822 276 13114	TACT SWITCH
1471	4822 130 91258	DISPLAY
1475	4822 276 13114	TACT SWITCH

DIODES

6401	4822 130 30621	1N4148
6402	4822 130 30621	1N4148
6403	4822 130 30621	1N4148
6404	4822 130 30621	1N4148
6405	4822 130 30621	1N4148
6406	4822 130 30621	1N4148
6407	4822 130 30621	1N4148
6408	4822 130 30621	1N4148
6409	4822 130 30621	1N4148
6410	4822 130 30621	1N4148
6411	4822 130 30621	1N4148
6412	4822 130 30621	1N4148
6413	4822 130 30621	1N4148
6414	4822 130 30621	1N4148
6415	4822 130 30621	1N4148
6416	4822 130 30621	1N4148
6418	4822 130 30621	1N4148
6419	4822 130 30621	1N4148
6420	4822 130 30621	1N4148
6421	4822 130 30621	1N4148

DIODES

6422	4822 130 30621	1N4148
6423	4822 130 30621	1N4148
6424	4822 130 30621	1N4148
6425	4822 130 30621	1N4148
6428	4822 130 34197	BZX79-C12 (UAW)
6432	4822 130 30861	BZX79-C7V5
6433	4822 130 30621	1N4148
6434	4822 130 30621	1N4148
6442	4822 130 82021	LTL307G
6453	4822 130 30621	1N4148

TRANSISTORS

7406	4822 130 40941	BC558
7408	4822 130 40938	BC548
7409	4822 130 41344	BC337-40
7410	4822 130 41344	BC337-40
7411	4822 130 41344	BC337-40
7412	4822 130 41344	BC337-40
7413	4822 130 40938	BC548
7421	4822 130 44196	BC548C
7423	4822 130 40941	BC558
7424	4822 130 41327	BC327-40
7427	4822 130 40938	BC548
7432	4822 130 40938	BC548
7433	4822 130 40938	BC548
7440	4822 130 40941	BC558
7441	4822 130 40941	BC558
7445	5322 130 44779	BC338-40
7446	5322 130 44779	BC338-40
7447	4822 130 44246	BC549C
7448	4822 130 44246	BC549C

INTEGRATED CIRCUITS

7403	4822 209 83274	NJM4560D
7407	4822 209 83274	NJM4560D
7415	4822 209 33436	TMP87CM20AF-2017
7418	4822 209 31508	ST24C01
7419	5322 209 10421	HEF4094BP
7420	5322 209 10421	HEF4094BP
7422	4822 214 52009	GP1U58XP
7425	5322 209 86518	MC7805CT

COILS

5401	5322 242 73697	CERAM.RES. 8MHz
5402	4822 157 50961	22 μ H
5403	4822 157 62552	COIL 2,2 μ H
5404	4822 157 62552	COIL 2,2 μ H
5405	4822 157 62552	COIL 2,2 μ H

RESISTORS

3401	4822 116 52244	15k	5%	0,5W
3402	4822 116 52244	15k	5%	0,5W
3403	4822 116 52234	100k	5%	0,5W
3404	4822 116 52234	100k	5%	0,5W
3405	4822 116 52283	4k7	5%	0,5W
3406	4822 116 52283	4k7	5%	0,5W
3407	4822 116 52243	1k5	5%	0,16W
3408	4822 116 52243	1k5	5%	0,16W
3409	4822 116 52263	2k7	5%	0,5W
3410	4822 116 52263	2k7	5%	0,5W
3413	4822 050 11002	1k	5%	0,2W
3414	4822 050 11002	1k	5%	0,2W
3415	4822 116 52233	10k	5%	0,5W
3416	4822 116 52233	10k	5%	0,5W
3417	4822 116 52284	47k	5%	0,5W
3418	4822 116 52284	47k	5%	0,5W
3419	4822 116 52284	47k	5%	0,5W
3420	4822 116 52284	47k	5%	0,5W
3421	4822 116 52284	47k	5%	0,5W
3422	4822 116 52284	47k	5%	0,5W
3423	4822 116 52284	47k	5%	0,5W
3424	4822 116 52284	47k	5%	0,5W
3425	4822 116 52224	470R	5%	0,5W
3426	4822 116 52224	470R	5%	0,5W
3427	4822 116 52257	22k	5%	0,5W
3428	4822 116 52257	22k	5%	0,5W
3431	4822 116 52263	2k7	5%	0,5W
3432	4822 116 52263	2k7	5%	0,5W
3433	4822 116 52276	3k9	5%	0,5W
3434	4822 116 52276	3k9	5%	0,5W
3435	4822 050 11002	1k	5%	0,2W
3436	4822 050 11002	1k	5%	0,2W
3437	4822 116 52276	3k9	5%	0,5W
3438	4822 116 52276	3k9	5%	0,5W
3439	4822 116 52224	470R	5%	0,5W
3440	4822 116 52224	470R	5%	0,5W
3441	4822 116 52224	470R	5%	0,5W
3442	4822 116 52224	470R	5%	0,5W
3443	4822 116 52291	56k	5%	0,5W
3444	4822 116 52291	56k	5%	0,5W
3445	4822 116 52271	33k	5%	0,16W
3446	4822 116 52271	33k	5%	0,16W
3447	4822 116 52271	33k	5%	0,16W
3448	4822 116 52271	33k	5%	0,16W
3449	4822 116 52264	27k	5%	0,5W
3450	4822 116 52264	27k	5%	0,5W
3451	4822 116 52271	33k	5%	0,16W
3452	4822 116 52271	33k	5%	0,16W
3453	4822 116 52238	12k	5%	0,5W
3454	4822 116 52238	12k	5%	0,5W
3455	4822 116 52271	33k	5%	0,16W
3456	4822 116 52271	33k	5%	0,16W
3457	4822 116 52264	27k	5%	0,5W
3458	4822 116 52264	27k	5%	0,5W
3459	4822 116 52271	33k	5%	0,16W
3460	4822 116 52271	33k	5%	0,16W
3461	4822 116 52271	33k	5%	0,16W
3462	4822 116 52271	33k	5%	0,16W
3463	4822 116 52285	470k	5%	0,5W
3464	4822 116 52285	470k	5%	0,5W

RESISTORS

3465	4822 116 52283	4k7	5%	0,5W
3466	4822 116 52283	4k7	5%	0,5W
3469	4822 116 52283	4k7	5%	0,5W
3470	4822 116 52283	4k7	5%	0,5W
3471	4822 116 52256	2k2	5%	0,16W
3472	4822 116 52256	2k2	5%	0,16W
3473	4822 116 52257	22k	5%	0,5W
3474	4822 116 52257	22k	5%	0,5W
3475	4822 116 52224	470R	5%	0,5W
3476	4822 116 52224	470R	5%	0,5W
3477	4822 116 52256	2k2	5%	0,16W
3478	4822 116 52283	4k7	5%	0,5W
3479	4822 101 21235	POTMETER 20k LIN		
3480	4822 101 90248	MOTORPOT (VOLUME)		
3481	4822 101 21102	Pot 2x 50k		
3482	4822 101 21102	Pot 2x 50k		
3483	4822 101 21102	Pot 2x 50k		
3484	4822 101 21102	Pot 2x 50k		
3485	4822 101 21102	Pot 2x 50k		
3486	4822 050 11002	1k	5%	0,2W
3487	4822 050 11002	1k	5%	0,2W
3488	4822 050 11002	1k	5%	0,2W
3489	4822 050 11002	1k	5%	0,2W
3490	4822 116 52215	220R	5%	0,16W
3491	4822 116 52233	10k	5%	0,5W
3492	4822 116 52228	680R	5%	0,5W
3493	4822 116 52215	220R	5%	0,16W
3494	4822 116 52215	220R	5%	0,16W
3495	4822 116 52215	220R	5%	0,16W
3496	4822 116 52215	220R	5%	0,16W
3497	4822 116 52257	22k	5%	0,5W
3498	4822 116 52233	10k	5%	0,5W
3499	4822 116 52215	220R	5%	0,16W
3500	4822 116 52217	270R	5%	0,5W
3501	4822 116 52269	3k3	5%	0,5W
3502	4822 050 11002	1k	5%	0,2W
3506	4822 116 52175	100R	5%	0,5W
3507	4822 116 52217	270R	5%	0,5W
3508	4822 116 52217	270R	5%	0,5W
3509	4822 116 52284	47k	5%	0,5W
3516	4822 116 52233	10k	5%	0,5W
3517	4822 116 52233	10k	5%	0,5W
3526	4822 116 52228	680R	5%	0,5W
3528	4822 116 52304	82k	5%	0,5W
3531	4822 116 52283	4k7	5%	0,5W
3532	4822 116 52283	4k7	5%	0,5W
3533	4822 116 52283	4k7	5%	0,5W
3534	4822 116 52283	4k7	5%	0,5W
3535	4822 116 52283	4k7	5%	0,5W
3536	4822 116 52283	4k7	5%	0,5W
3537	4822 116 52217	270R	5%	0,5W
3538	4822 116 52217	270R	5%	0,5W
3539	4822 116 52217	270R	5%	0,5W
3540	4822 116 52258	220k	5%	0,5W
3550	4822 050 11002	1k	5%	0,2W
3553	4822 050 11002	1k	5%	0,2W
3554	4822 116 52233	10k	5%	0,5W
3555	4822 116 52233	10k	5%	0,5W
3556	4822 116 52233	10k	5%	0,5W
3557	4822 116 52233	10k	5%	0,5W

RESISTORS

3558	4822 116 52256	2k2	5%	0,16W
3559	4822 116 52256	2k2	5%	0,16W
3560	4822 116 52283	4k7	5%	0,5W
3562	4822 050 11002	1k	5%	0,2W
3563	4822 116 52233	10k	5%	0,5W
3564	4822 050 11002	1k	5%	0,2W
3565	4822 050 11002	1k	5%	0,2W
3568	4822 116 52233	10k	5%	0,5W
3573	4822 050 11002	1k	5%	0,2W
3574	4822 116 52284	47k	5%	0,5W
3575	4822 050 11002	1k	5%	0,2W
3576	4822 116 52271	33k	5%	0,16W
3577	4822 116 52233	10k	5%	0,5W
3578	4822 116 52233	10k	5%	0,5W
3579	4822 116 52233	10k	5%	0,5W
3580	4822 116 52233	10k	5%	0,5W
3581	4822 116 52233	10k	5%	0,5W
3582	4822 116 52233	10k	5%	0,5W
3583	4822 116 52233	10k	5%	0,5W
3585	4822 116 52249	1k8	5%	0,16W
3586	4822 116 52175	100R	5%	0,5W
3587	4822 116 52175	100R	5%	0,5W
3589	4822 050 11002	1k	5%	0,2W
3590	4822 116 52257	22k	5%	0,5W
3591	4822 050 11002	1k	5%	0,2W
3592	4822 116 52257	22k	5%	0,5W
3593	4822 050 11002	1k	5%	0,2W
3594	4822 116 52224	470R	5%	0,5W
3595	4822 116 52224	470R	5%	0,5W
3596	4822 116 52224	470R	5%	0,5W
3597	4822 116 52224	470R	5%	0,5W
3598	4822 116 52256	2k2	5%	0,16W
3601	4822 116 52224	470R	5%	0,5W
3602	4822 116 52224	470R	5%	0,5W
3603	4822 050 11002	1k	5%	0,2W
3604	4822 050 11002	1k	5%	0,2W
3605	4822 116 52217	270R	5%	0,5W
3606	4822 116 52217	270R	5%	0,5W
3607	4822 050 11002	1k	5%	0,2W
3608	4822 050 11002	1k	5%	0,2W
3609	4822 050 11002	1k	5%	0,2W
3610	4822 116 52215	220R	5%	0,16W
3612	4822 116 52256	2k2	5%	0,16W
3613	4822 050 11002	1k	5%	0,2W
3615	4822 116 52224	470R	5%	0,5W
3616	4822 116 52215	220R	5%	0,16W
3617	4822 116 52228	680R	5%	0,5W
3618	4822 116 52233	10k	5%	0,5W
3621	4822 116 52224	470R	5%	0,5W
3622	4822 116 52224	470R	5%	0,5W
3623	4822 116 52224	470R	5%	0,5W
3624	4822 116 52224	470R	5%	0,5W
3649	4822 050 22205	2M2	1%	0,6W
3650	4822 050 22205	2M2	1%	0,6W
3651	4822 116 52257	22k	5%	0,5W
3652	4822 116 52257	22k	5%	0,5W
3653	4822 116 52235	1M	5%	0,5W
3654	4822 116 52235	1M	5%	0,5W
3655	4822 116 52224	470R	5%	0,5W
3660	4822 116 52234	100k	5%	0,5W

RESISTORS

3661	4822 116 52234	100k	5%	0,5W
3662	4822 116 52224	470R	5%	0,5W
3663	4822 116 52224	470R	5%	0,5W
3664	4822 116 52228	680R	5%	0,5W
3665	4822 116 52256	2k2	5%	0,16W
3666	4822 116 52234	100k	5%	0,5W
3667	4822 116 52234	100k	5%	0,5W
3668	4822 050 11002	1k	5%	0,2W
3670	4822 116 52304	82k	5%	0,5W
3671	4822 116 52304	82k	5%	0,5W
3672	4822 050 11002	1k	5%	0,2W

CAPACITORS

2401	4822 124 40239	0,47µF	20%	63V
2402	4822 124 40239	0,47µF	20%	63V
2403	4822 124 40239	0,47µF	20%	63V
2404	4822 124 40239	0,47µF	20%	63V
2405	4822 124 40239	0,47µF	20%	63V
2406	4822 124 40239	0,47µF	20%	63V
2407	4822 124 40239	0,47µF	20%	63V
2408	4822 124 40239	0,47µF	20%	63V
2409	4822 122 33848	47pF	5%	50V
2410	4822 122 33848	47pF	5%	50V
2411	4822 122 33848	47pF	5%	50V
2412	4822 122 33848	47pF	5%	50V
2413	4822 122 33848	47pF	5%	50V
2414	4822 122 33848	47pF	5%	50V
2415	4822 122 33848	47pF	5%	50V
2416	4822 122 33848	47pF	5%	50V
2417	4822 126 12702	270pF	10%	50V
2418	4822 126 12702	270pF	10%	50V
2419	4822 122 33195	100pF	10%	50V
2420	4822 122 33195	100pF	10%	50V
2421	4822 122 33848	47pF	5%	50V
2422	4822 122 33848	47pF	5%	50V
2425	4822 122 33195	100pF	10%	50V
2426	4822 122 33195	100pF	10%	50V
2427	4822 124 40242	1µF	20%	63V
2428	4822 124 40242	1µF	20%	63V
2429	4822 126 12702	270pF	10%	50V
2430	4822 126 12702	270pF	10%	50V
2431	4822 122 33197	1nF	10%	50V
2432	4822 122 33197	1nF	10%	50V
2433	4822 122 33197	1nF	10%	50V
2434	4822 122 33197	1nF	10%	50V
2435	4822 126 11714	4,7nF	20%	50V
2436	4822 126 11714	4,7nF	20%	50V
2437	4822 126 11714	4,7nF	20%	50V
2438	4822 126 11714	4,7nF	20%	50V
2439	4822 126 11585	22nF		50V
2440	4822 126 11585	22nF		50V
2441	4822 126 11585	22nF		50V
2442	4822 126 11585	22nF		50V
2443	4822 121 43526	47nF	5%	100V
2444	4822 121 43526	47nF	5%	100V
2445	4822 121 42408	220nF	5%	63V
2446	4822 121 42408	220nF	5%	63V
2449	4822 122 33195	100pF	10%	50V

POWER BOARD**CAPACITORS**

2450	4822 122 33195	100pF	10%	50V
2451	4822 124 40246	4,7μF	20%	63V
2452	4822 124 40246	4,7μF	20%	63V
2453	4822 121 51387	10nF	20%	16V
2454	4822 121 51387	10nF	20%	16V
2455	4822 122 33192	27pF	5%	50V
2456	4822 122 33192	27pF	5%	50V
2459	4822 124 40242	1μF	20%	63V
2460	4822 124 40239	0,47μF	20%	63V
2461	4822 126 11585	22nF		50V
2462	4822 126 11585	22nF		50V
2463	4822 126 11585	22nF		50V
2464	4822 124 41525	100μF	20%	25V
2465	4822 124 22263	220μF	20%	25V
2466	4822 124 40248	10μF	20%	63V
2468	4822 124 40433	47μF	20%	25V
2469	4822 124 40242	1μF	20%	63V
2470	4822 124 40242	1μF	20%	63V
2471	4822 122 33519	470pF	10%	50V
2472	4822 122 33519	470pF	10%	50V
2473	4822 124 40433	47μF	20%	25V
2475	4822 124 22263	220μF	20%	25V
2476	4822 124 41525	100μF	20%	25V
2477	4822 124 40433	47μF	20%	25V
2480	4822 124 40242	1μF	20%	63V
2481	4822 124 40242	1μF	20%	63V
2483	4822 122 33197	1nF	10%	50V
2484	4822 122 33197	1nF	10%	50V
2485	4822 122 33197	1nF	10%	50V
2502	4822 124 41525	100μF	20%	25V
2503	4822 124 41525	100μF	20%	25V
2504	5322 124 21643	22μF	20%	40V
2507	4822 126 12702	270pF	10%	50V
2510	4822 122 33848	47pF	5%	50V
2512	4822 124 40242	1μF	20%	63V
2514	4822 126 12702	270pF	10%	50V
2551	4822 124 41525	100μF	20%	25V
2552	4822 122 10466	220pF	10%	
2553	4822 122 10466	220pF	10%	
2554	4822 122 33197	1nF	10%	50V
2555	4822 122 33197	1nF	10%	50V
2556	4822 122 33195	100pF	10%	50V
2557	4822 122 33195	100pF	10%	50V
2558	5322 121 42386	100nF	5%	63V

MECHANICAL PARTS

4822 255 40128	CLIP TO126
5322 255 40397	CLIP IC

MISCELLANEOUS

1304 4822 267 31176	SPEAKER TERMINAL
1305 4822 264 30175	SOCKET EXT. SUPPLY

DIODES

6212 4822 130 30621	1N4148
6250 4822 130 82079	D3SBA20
6251 4822 130 30621	1N4148
6252 4822 130 30621	1N4148
6253 4822 130 34174	BZX79-B4V7
6254 4822 130 30621	1N4148
6257 5322 130 30684	1N4002
6258 5322 130 30684	1N4002
6259 4822 130 30621	1N4148
6261 5322 130 30684	1N4002
6350 4822 130 30621	1N4148
6351 4822 130 30621	1N4148
6354 4822 130 30621	1N4148

TRANSISTORS

7250 4822 130 40937	BC548B
7252 4822 130 40917	BD238(UAW)
7253 4822 130 40937	BC548B
7254 4822 130 40937	BC548B
7255 4822 130 44197	BC558B
7309 4822 130 40937	BC548B
7310 4822 130 40937	BC548B
7311 4822 130 41344	BC337-40
7312 4822 130 41344	BC337-40
7352 4822 130 40937	BC548B

INTEGRATED CIRCUITS

7313 4822 209 73356	AN7161N(FP)
7314 4822 209 73356	AN7161N(FP)

COILS

5309 4822 157 62552	COIL 2,2μH
5311 4822 157 62552	COIL 2,2μH
5312 4822 157 62552	COIL 2,2μH
5315 4822 157 62552	COIL 2,2μH
5316 4822 157 62552	COIL 2,2μH

RESISTORS

3250 4822 050 11002	1k	5%	0,2W
3251 4822 116 52233	10k	5%	0,5W
3252 4822 116 52233	10k	5%	0,5W
3254 4822 116 52271	33k	5%	0,16W
3255 4822 050 11002	1k	5%	0,2W

RESISTORS

3256	4822 050 11002	1k	5%	0,2W
3257	4822 116 52233	10k	5%	0,5W
3258	4822 116 52283	4k7	5%	0,5W
3259	4822 116 52271	33k	5%	0,16W
3260	4822 116 52233	10k	5%	0,5W
3261	4822 116 52291	56k	5%	0,5W
3262	4822 050 11002	1k	5%	0,2W
3263	4822 116 52283	4k7	5%	0,5W
3264	4822 116 52217	270R	5%	0,5W
3307	4822 116 52256	2k2	5%	0,16W
3308	4822 116 52256	2k2	5%	0,16W
3309	4822 050 11002	1k	5%	0,2W
3310	4822 050 11002	1k	5%	0,2W
3311	4822 050 11002	1k	5%	0,2W
3312	4822 050 11002	1k	5%	0,2W
3313	4822 116 52256	2k2	5%	0,16W
3314	4822 116 52256	2k2	5%	0,16W
3315	4822 116 52233	10k	5%	0,5W
3316	4822 116 52233	10k	5%	0,5W
3317	4822 116 52213	180R	5%	0,5W
3318	4822 116 52213	180R	5%	0,5W
3319	4822 052 10228	2R2	5%	0,33W
3320	4822 052 10228	2R2	5%	0,33W
3321	4822 052 10228	2R2	5%	0,33W
3322	4822 052 10228	2R2	5%	0,33W
3323	4822 116 52175	100R	5%	0,5W
3324	4822 116 52175	100R	5%	0,5W
3325	4822 116 52175	100R	5%	0,5W
3326	4822 116 52175	100R	5%	0,5W
3350	4822 052 10479	47R	5%	0,3W
3354	4822 116 52234	100k	5%	0,5W
3355	4822 116 52217	270R	5%	0,5W

CAPACITORS

2208	4822 124 41525	100μF	20%	25V
2250	5322 121 42578	100nF	10%	100V
2251	5322 121 42386	100nF	5%	63V
2252	5322 121 42386	100nF	5%	63V
2253	4822 124 41995	6800μF	20%	25V
2254	4822 124 40242	1μF	20%	63V
2255	4822 122 33197	1nF	10%	50V
2256	4822 126 11585	22nF	50V	
2257	5322 121 42578	100nF	10%	100V
2259	5322 121 42386	100nF	5%	63V
2260	4822 124 22412	2200μF	20%	16V
2262	4822 124 41525	100μF	20%	25V
2265	4822 124 41994	3300μF	20%	16V
2266	4822 122 33197	1nF	10%	50V
2267	4822 122 33197	1nF	10%	50V
2311	4822 124 40242	1μF	20%	63V
2312	4822 124 40242	1μF	20%	63V
2315	5322 121 42489	33nF	5%	100V
2316	5322 121 42489	33nF	5%	100V
2317	4822 124 40248	10μF	20%	63V
2318	4822 124 40248	10μF	20%	63V
2319	4822 124 40433	47μF	20%	25V
2320	4822 124 40433	47μF	20%	25V
2321	4822 122 33169	680pF	10%	50V
2322	4822 122 33169	680pF	10%	50V

CAPACITORS

2323	4822 126 12878	1,5nF	10%	16V
2324	4822 126 12878	1,5nF	10%	16V
2325	4822 124 41525	100μF	20%	25V
2326	4822 124 41525	100μF	20%	25V
2329	5322 124 41431	22μF	20%	25V
2330	5322 124 41431	22μF	20%	25V
2333	4822 124 40433	47μF	20%	25V
2334	4822 124 40433	47μF	20%	25V
2335	4822 124 40433	47μF	20%	25V
2336	4822 124 40433	47μF	20%	25V
2337	4822 121 42408	220nF	5%	63V
2338	4822 121 42408	220nF	5%	63V
2339	4822 121 42408	220nF	5%	63V
2340	4822 121 42408	220nF	5%	63V
2350	4822 124 41525	100μF	20%	25V
2351	5322 121 42386	100nF	5%	63V
2352	5322 121 42386	100nF	5%	63V
2353	5322 121 42386	100nF	5%	63V
2354	4822 124 40242	1μF	20%	63V
2355	4822 126 12519	330pF	10%	50V
2356	4822 126 12519	330pF	10%	50V
2361	4822 121 51387	10nF	20%	16V
2362	4822 121 51387	10nF	20%	16V

TRANSFORMER BOARD**MISCELLANEOUS**

1250	4822 071 55002	FUSE T5A
1251	4822 071 56301	Fuse T 630mA/250V
1252	4822 071 56301	Fuse T 630mA/250V
1255	4822 265 31015	MAINS SOCKET
1260	4822 272 10269	VOLTAGE SELECTOR

5250	4822 146 31235	TRAFO AS445/21, /30
------	----------------	---------------------

COILS

5251	4822 157 70003	COIL, MAINS FILTER
------	----------------	--------------------

RECORDER BOARD**MECHANICAL PARTS**

4822 403 30772	REC. LEVER
4822 492 70426	REC SPRING
4822 466 92641	DISTANCE SOCKET
4822 404 21073	PRINTED BOARD SNAP

MISCELLANEOUS

1707	4822 277 20594	SWITCH
------	----------------	--------

DIODES

6701	4822 130 30621	1N4148
6702	4822 130 30621	1N4148
6704	4822 130 30621	1N4148
6705	4822 130 30621	1N4148
6706	4822 130 30621	1N4148

6707	4822 130 30621	1N4148
6710	4822 130 30621	1N4148
6712	4822 130 30621	1N4148

TRANSISTORS

7703	4822 130 40937	BC548B
7704	4822 130 40937	BC548B
7705	4822 130 40937	BC548B
7706	5322 130 44779	BC338-40
7707	5322 130 44779	BC338-40

7708	4822 130 44197	BC558B
7709	4822 130 40937	BC548B
7712	4822 130 44196	BC548C
7713	4822 130 44197	BC558B
7753	4822 130 40937	BC548B

7756	5322 130 44779	BC338-40
7757	5322 130 44779	BC338-40

INTEGRATED CIRCUITS

7701	4822 209 72491	KA2224
7702	4822 209 70288	UPC1313HA

COILS

5701	4822 157 51238	820μH
5702	4822 157 51238	820μH

RESISTORS

3701	4822 116 52224	470R	5%	0,5W
3702	4822 116 52224	470R	5%	0,5W
3703	4822 116 52224	470R	5%	0,5W
3704	4822 116 52258	220k	5%	0,5W
3705	4822 116 52188	27R	5%	0,5W

3706	4822 116 52175	100R	5%	0,5W
3709	4822 116 52175	100R	5%	0,5W
3710	4822 116 52289	5k6	5%	0,16W
3711	4822 116 52234	100k	5%	0,5W
3712	4822 116 52251	18k	5%	0,5W

RESISTORS

3713	4822 116 52296	6k8	5%	0,5W
3715	4822 116 52257	22k	5%	0,5W
3716	4822 050 11002	1k	5%	0,2W
3717	4822 116 52256	2k2	5%	0,16W
3718	4822 116 52224	470R	5%	0,5W
3719	4822 116 52257	22k	5%	0,5W
3720	4822 116 52224	470R	5%	0,5W
3721	4822 116 52224	470R	5%	0,5W
3722	4822 116 52224	470R	5%	0,5W
3723	4822 116 52224	470R	5%	0,5W
3724	4822 116 52258	220k	5%	0,5W
3725	4822 116 52175	100R	5%	0,5W
3727	4822 116 81682	2M2	5%	0,5W
3730	4822 050 11002	1k	5%	0,2W
3731	4822 116 52207	1k2	5%	0,5W
3732	4822 116 52233	10k	5%	0,5W
3733	4822 116 52207	1k2	5%	0,5W
3734	4822 116 52233	10k	5%	0,5W
3735	4822 116 52238	12k	5%	0,5W
3736	4822 116 52264	27k	5%	0,5W
3737	4822 116 52224	470R	5%	0,5W
3738	4822 116 52257	22k	5%	0,5W
3739	4822 116 52224	470R	5%	0,5W
3741	4822 050 11002	1k	5%	0,2W
3742	4822 050 11002	1k	5%	0,2W
3743	4822 116 52257	22k	5%	0,5W
3744	4822 116 52258	220k	5%	0,5W
3745	4822 116 52234	100k	5%	0,5W
3746	4822 116 52224	470R	5%	0,5W
3747	4822 116 52234	100k	5%	0,5W
3749	4822 116 52283	4k7	5%	0,5W
3751	4822 116 52224	470R	5%	0,5W
3752	4822 116 52224	470R	5%	0,5W
3753	4822 116 52224	470R	5%	0,5W
3754	4822 116 52258	220k	5%	0,5W
3755	4822 116 52188	27R	5%	0,5W
3756	4822 050 11002	1k	5%	0,2W
3760	4822 116 52289	5k6	5%	0,16W
3761	4822 116 52234	100k	5%	0,5W
3763	4822 116 52296	6k8	5%	0,5W
3765	4822 116 52257	22k	5%	0,5W
3766	4822 050 11002	1k	5%	0,2W
3767	4822 116 52256	2k2	5%	0,16W
3768	4822 116 52224	470R	5%	0,5W
3769	4822 116 52257	22k	5%	0,5W
3770	4822 116 52224	470R	5%	0,5W
3771	4822 116 52224	470R	5%	0,5W
3772	4822 116 52224	470R	5%	0,5W
3773	4822 116 52224	470R	5%	0,5W
3774	4822 116 52258	220k	5%	0,5W
3775	4822 116 52175	100R	5%	0,5W
3778	4822 052 10189	18R	5%	0,33W
3779	4822 116 52298	680k	5%	0,5W
3780	4822 050 11002	1k	5%	0,2W
3781	4822 116 52207	1k2	5%	0,5W

RESISTORS

3782	4822 050 11002	1k	5%	0,2W
3783	4822 116 52258	220k	5%	0,5W
3785	4822 116 52238	12k	5%	0,5W
3786	4822 116 52264	27k	5%	0,5W
3788	4822 116 52257	22k	5%	0,5W
3789	4822 116 52224	470R	5%	0,5W
3791	4822 050 11002	1k	5%	0,2W
3792	4822 050 11002	1k	5%	0,2W
3796	4822 116 52257	22k	5%	0,5W
3797	4822 050 11002	1k	5%	0,2W
3798	4822 116 52231	820R	5%	0,5W
3799	4822 116 52234	100k	5%	0,5W

CAPACITORS

2701	4822 126 10178	820pF	10%	50V
2702	4822 122 33195	100pF	10%	50V
2703	4822 124 41643	100µF	20%	16V
2704	4822 126 11595	470pF	10%	50V
2705	4822 126 11325	4,7nF	10%	50V
2706	4822 124 40433	47µF	20%	25V
2708	4822 124 40248	10µF	20%	63V
2709	4822 121 41857	10nF	5%	250V
2711	4822 124 22633	22µF	20%	35V
2712	4822 126 11714	4,7nF	20%	
2713	4822 124 40433	47µF	20%	25V
2720	4822 126 12878	1,5nF	10%	16V
2721	4822 126 12877	1,2nF	10%	50V
2722	4822 124 22466	1µF	20%	50V
2723	4822 124 22633	22µF	20%	35V
2724	4822 126 11595	470pF	10%	50V
2725	4822 124 40433	47µF	20%	25V
2726	4822 124 40433	47µF	20%	25V
2728	4822 124 40248	10µF	20%	63V
2730	4822 126 11325	4,7nF	10%	50V
2731	4822 121 41857	10nF	5%	250V
2732	4822 122 33197	1nF	10%	50V
2751	4822 126 10178	820pF	10%	50V
2753	4822 124 41643	100µF	20%	16V
2754	4822 126 11595	470pF	10%	50V
2758	4822 124 40248	10µF	20%	63V
2759	4822 121 41857	10nF	5%	250V
2762	4822 126 11714	4,7nF	20%	
2770	4822 126 12878	1,5nF	10%	16V
2771	4822 126 12877	1,2nF	10%	50V
2772	4822 124 22466	1µF	20%	50V
2773	4822 124 22633	22µF	20%	35V
2774	4822 126 11595	470pF	10%	50V
2775	4822 124 40184	1000µF	20%	10V
2778	4822 124 40248	10µF	20%	63V
2781	4822 121 41857	10nF	5%	250V
2782	4822 122 33197	1nF	10%	50V
2783	4822 121 41935	12nF	5%	250V
2784	4822 124 40242	1µF	20%	63V
2785	4822 121 51305	15nF	10%	50V
2786	4822 122 33195	100pF	10%	50V
2788	4822 124 40433	47µF	20%	25V
2789	4822 124 40433	47µF	20%	25V
2790	4822 124 40433	47µF	20%	25V
2791	4822 124 40196	220µF	20%	16V

Micro Mix Board**MISCELLANEOUS**

1900	4822 267 40659	MICROPHONE SOCKET
------	----------------	-------------------

INTEGRATED CIRCUITS

7900	4822 209 83274	NJM4560D
------	----------------	----------

RESISTORS

3900	4822 116 52256	2k2	5%	0,16W
3901	4822 116 52175	100R	5%	0,5W
3902	4822 116 52224	470R	5%	0,5W
3903	4822 116 52234	100k	5%	0,5W
3904	4822 116 52234	100k	5%	0,5W
3905	4822 100 30191	Potmeter 20k Log.		
3906	4822 116 52175	100R	5%	0,5W
3907	4822 116 52234	100k	5%	0,5W
3908	4822 116 52238	12k	5%	0,5W
3909	4822 116 52233	10k	5%	0,5W
3910	4822 116 52224	470R	5%	0,5W
3911	4822 116 52238	12k	5%	0,5W
3912	4822 116 52303	8k2	5%	0,5W

CAPACITORS

2900	4822 124 40242	1μF	20%	63V
2901	4822 122 33195	100pF	10%	50V
2902	4822 122 33519	470pF	10%	50V
2903	4822 122 33848	47pF	5%	50V
2904	4822 124 40248	10μF	20%	63V
2905	4822 122 33848	47pF	5%	50V
2906	4822 122 33848	47pF	5%	50V
2907	4822 124 40248	10μF	20%	63V
2908	4822 124 40248	10μF	20%	63V
2909	4822 122 33195	100pF	10%	50V
2910	4822 122 33519	470pF	10%	50V
2911	4822 122 33848	47pF	5%	50V
2912	4822 126 12787	330pF	10%	50V
2913	4822 124 40242	1μF	20%	63V
2914	4822 122 33848	47pF	5%	50V
2915	4822 124 40248	10μF	20%	63V
2916	4822 124 40248	10μF	20%	63V
2917	4822 124 41525	100μF	20%	25V
2918	4822 126 11585	22nF	10%	50V
2919	4822 124 40433	47μF	20%	25V

Spectrum Analyzer Board**DIODES**

6500	4822 130 30621	1N4148
6501	4822 130 30621	1N4148
6502	4822 130 30621	1N4148
6503	4822 130 30621	1N4148

INTEGRATED CIRCUITS

7550	4822 209 31515	BA3830S
7551	4822 209 32527	E-PROM AS540

COILS

5505	4822 242 81525	CERAMIC RES. 2MHz
------	----------------	-------------------

RESISTORS

3560	4822 050 11002	1k5%	5%	0,2W
3561	4822 050 11002	1k5%	5%	0,2W
3562	4822 116 52265	270k	5%	0,5W
3563	4822 116 52265	270k	5%	0,5W
3564	4822 116 52251	18k	5%	0,5W
3565	4822 116 52233	10k	5%	0,5W
3566	4822 116 52233	10k	5%	0,5W
3567	4822 116 52233	10k	5%	0,5W
3568	4822 116 52233	10k	5%	0,5W
3569	4822 116 52233	10k	5%	0,5W
3573	4822 116 52224	470R	5%	0,5W
3564	4822 116 52233	10k	5%	0,5W
3575	4822 116 52175	100R	5%	0,5W
3576	4822 116 52233	10k	5%	0,5W
3577	4822 116 52251	18k	5%	0,5W

CAPACITORS

2550	4822 124 41525	100μF	20%	25V
2552	4822 122 33197	1nF	10%	50V
2553	4822 124 41525	100μF	20%	25V
2554	4822 121 42408	220nF	5%	63V
2555	4822 126 11585	22nF	5%	50V
2556	4822 122 33191	22pF	5%	50V

Accessories & Set parts**MISCELLANEOUS**

4822 445 10366	LS BOX
4822 303 50063	FM AERIAL
4822 218 10513	IR REMOTE CONTROL
4822 321 10831	MAINS CORD /21
4822 321 10954	MAINS CORD /30

DIODES

1006	4822 130 83092	LED (Volume pot)
------	----------------	------------------

Service Service Service

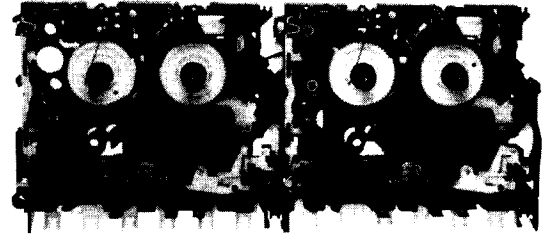

44 992 A11

For details and exploded view see Service Manual of tape transport RN/RR, RDN/RDR (general documentation)

Service Manual

(GB) MAINTENANCE

It is recommended to clean the recorder after approx. 500 hours of operation.

To be cleaned with alcohol or spirit

- Erase head
- Recording/playback head
- Capstan
- Pressure roller

(F) ENTRETIEN

L'appareil devra être nettoyé après env. 500 heures de marche aux points les plus importants.

Nettoyer les éléments suivants à l'alcool ou à l'alcool à brûler:

- Tête effacement
- Tête enregistrement/reproduction
- Cabestan
- Galet presseur

(NL) ONDERHOUD

Aanbevolen wordt het apparaat na ca. 500 bedrijfsuren schoon te maken

Schoonmaken met alcohol of spiritus:

- Wiskop
- Opneem-/weergeefkop
- Toonas
- Drukrol

(D) WARTUNG

Es empfiehlt sich, das Gerät nach ca. 500 Betriebsstunden zu reinigen

Reinigen mit Alkohol oder Spiritus:

- Löschkopf
- Aufnahme/Wiedergabe-Kopf
- Tonachse
- Andruckrolle

(I) MANUTENZIONE

E consigliabile pulire l'apparecchio dopo circa 500 ore di funzionamento ai punti principali.

Pulire con alcool

- Testina di cancellazione
- Testina di registrazione/riproduzione
- Capstan
- Rullo preminastro

*Pour votre sécurité, ces documents doivent être utilisés par des spécialistes agréés, seuls habilités à réparer votre appareil en panne.



SPECIAL FEATURES

GB CONTINUOUS PLAY

Definition: "Play" starts on deck A (play back deck). After tape end on deck A, deck B (REC/PB – deck) will be going on with "Play" till tape end. Then both decks will be in "Stop" – mode due to full auto shut off.

Operating sequence:

- 1) start with "Play" on deck A
- 2) switch "Pause" on deck B
- 3) switch "Play" on deck B

After tape end on deck A auto stop – mechanism is working. The locked "play" – button on deck A and the "pause" – button on deck B will be released. "Play" – mode on deck B will now be active. After tape end on deck B full auto shut off will be activated.

SYNCHRO START

"COPY" from deck A to deck B

Operating sequence:

- 1) switch "Pause" on deck B
- 2) switch "REC" (one touch) on deck B
- 3) switch "Play" on deck A

In that moment when the "play" – button on deck A will be depressed the "pause" – button on deck B will be released. Now "REC" – mode on deck B will be active. Both decks will be working.

If one of the cassettes reaches tape end full auto shut off will be activated and COPY is finished.

NL ONONDERBROKEN WEERGEVEN

Omschrijving: Het weergeven begint op deck A (weergavedeck). Nadat op deck A het einde van de band is bereikt, gaat het weergeven door op deck B (opname/weergave-deck). Op dat moment worden beide decks geheel automatisch in de stand "Stop" geschakeld. Bedieningsvolgorde:

- 1) druk op toets "Play" op deck A
- 2) druk op toets "Pause" op deck B
- 3) druk op toets "Play" op deck B

Nadat het einde van de band op deck A is bereikt, treedt het autostop-mechanisme in werking. De vergrendelde toets "Play" op deck A en de toets "Pause" op deck B worden dan vrijgegeven. De stand "Play" op deck B is nu geactiveerd. Nadat het einde van de band op deck B is bereikt, wordt de volledig automatische uitschakeling geactiveerd.

SYNCHROON STARTEN

"KOPIEREN" van deck A naar deck B

Bedieningsvolgorde:

- 1) druk op toets "Pause" op deck B
- 2) druk (een keer) op toets "REC" op deck B
- 3) druk op toets "Play" op deck A

Op het moment dat de toets "Play" op deck A wordt ingedrukt, wordt de toets "Pause" op deck B vrijgegeven. De stand "REC" op deck B is nu geactiveerd. Beide decks zijn in werking.

Indien op een van de cassettes het einde van de band wordt bereikt, wordt de volledig automatische uitschakeling geactiveerd en het kopiëren beëindigd.

F LECTURE EN CONTINU

Définition: La lecture ("play") démarre sur la platine A (platine de lecture). A l'arrivée en fin de bande sur la platine A, la platine B (platine d'enregistrement/lecture) poursuivra la lecture ("play") jusqu'à la fin de la bande. Ensuite, les deux platines seront en mode arrêt ("stop") grâce à l'arrêt total automatique.

Ordre de fonctionnement :

- 1) mettez en marche avec "Play" sur la platine A
- 2) appuyez sur "Pause" sur la platine B
- 3) appuyez sur "Play" sur la platine B

Après l'arrivée en fin de bande sur la platine A, le mécanisme d'arrêt automatique entre en fonctionnement. Les touches verrouillées "play" sur la platine A et "pause" sur la platine B sont alors débloquées. Le mode lecture ("play") sur la platine B est à présent actif. Après l'arrivée en fin de bande sur la platine B, l'arrêt total automatique sera activé. Lorsque la touche de "sélection de mode" est en position 2 (inversée), il est alors possible d'écouter trois faces de deux cassettes en continu.

DEPART SYNCHRONISE

Pour la COPIE de la platine A vers la platine B

Ordre de fonctionnement :

- 1) appuyez sur "Pause" sur la platine B
- 2) appuyez sur "REC" (enregistrement à une touche) sur la platine B
- 3) appuyez sur "Play" sur la platine A

Au moment où la touche "play" (lecture) sur la platine A sera enfoncée, la touche "pause" sur la platine B sera délogée. Le mode "REC" (enregistrement) sur la platine B est à présent actif. Les deux platines fonctionnent. Si l'une des cassettes arrive en fin de bande, l'arrêt total automatique sera activé et la COPIE terminée.

D CONTINUOUS PLAY

Definition: "Play" beginnt auf Laufwerk A (Wiedergabe – Laufwerk). Am Bandende von Laufwerk A setzt Laufwerk B (Aufn./Wg – Laufwerk) mit "Play" fort und läuft bis Bandende. Danach sind beide Laufwerke abgeschaltet. Bedienungsablauf:

- 1) "Play" – Taste auf Laufwerk A drücken
- 2) "Pause" – Taste auf Laufwerk B drücken
- 3) "Play" – Taste auf Laufwerk B drücken

Am Bandende von Laufwerk A arbeitet der Auto stop – Mechanismus. Die "Play" – Taste von Laufwerk A und die "Pause" – Taste von Laufwerk B werden gelöst. Auf Laufwerk B ist nun die "Play" – Funktion eingeschaltet. Am Bandende von Laufwerk B schaltet die automatische Endabschaltung ab.

SYNCHRO START

"Kopieren" von Laufwerk A auf Laufwerk B.

Bedienungsablauf:

- 1) "Pause" – Taste von Laufwerk B drücken
- 2) "REC" – Taste (one touch) von Laufwerk B drücken
- 3) "Play" – Taste von Laufwerk A drücken

In dem Moment wo die "Play" – Taste von Laufwerk A gedrückt wird, wird die "Pause" – Taste von Laufwerk B gelöst. "Aufnahme" – Modus wird dadurch auf Laufwerk B aktiviert und beide Laufwerke arbeiten. Erreicht eine der beiden Kassetten das Bandende, schaltet die automatische Endabschaltung ab und der Kopierbetrieb wird beendet.

I RIPRODUZIONE CONTINUA

Funzionamento: la riproduzione inizia con la cassetta nel riproduttore A. Alla fine del nastro della cassetta nel riproduttore A, la riproduzione viene continuata con la cassetta nel registratore/riproduttore B. In tale momento, ambedue gli apparecchi vengono commutati automaticamente nel modo di arresto.

Ordine di comando:

- 1) premere il tasto "Play" sul riproduttore A
 - 2) premere il tasto "Pause" sul registratore/riproduttore B
 - 3) premere il tasto "Play" sul registratore/riproduttore B
- Alla fine del nastro della cassetta nel riproduttore A, viene attivato il meccanismo di arresto automatico dello stesso. Viene rilasciato il tasto "Play" sul riproduttore A ed il tasto "Pause" sul registratore/riproduttore B. Viene avviata la riproduzione della cassetta nel registratore/riproduttore B. Quando è stata raggiunta la fine del nastro della cassetta nel registratore/riproduttore B, ambedue gli apparecchi vengono arrestati automaticamente.

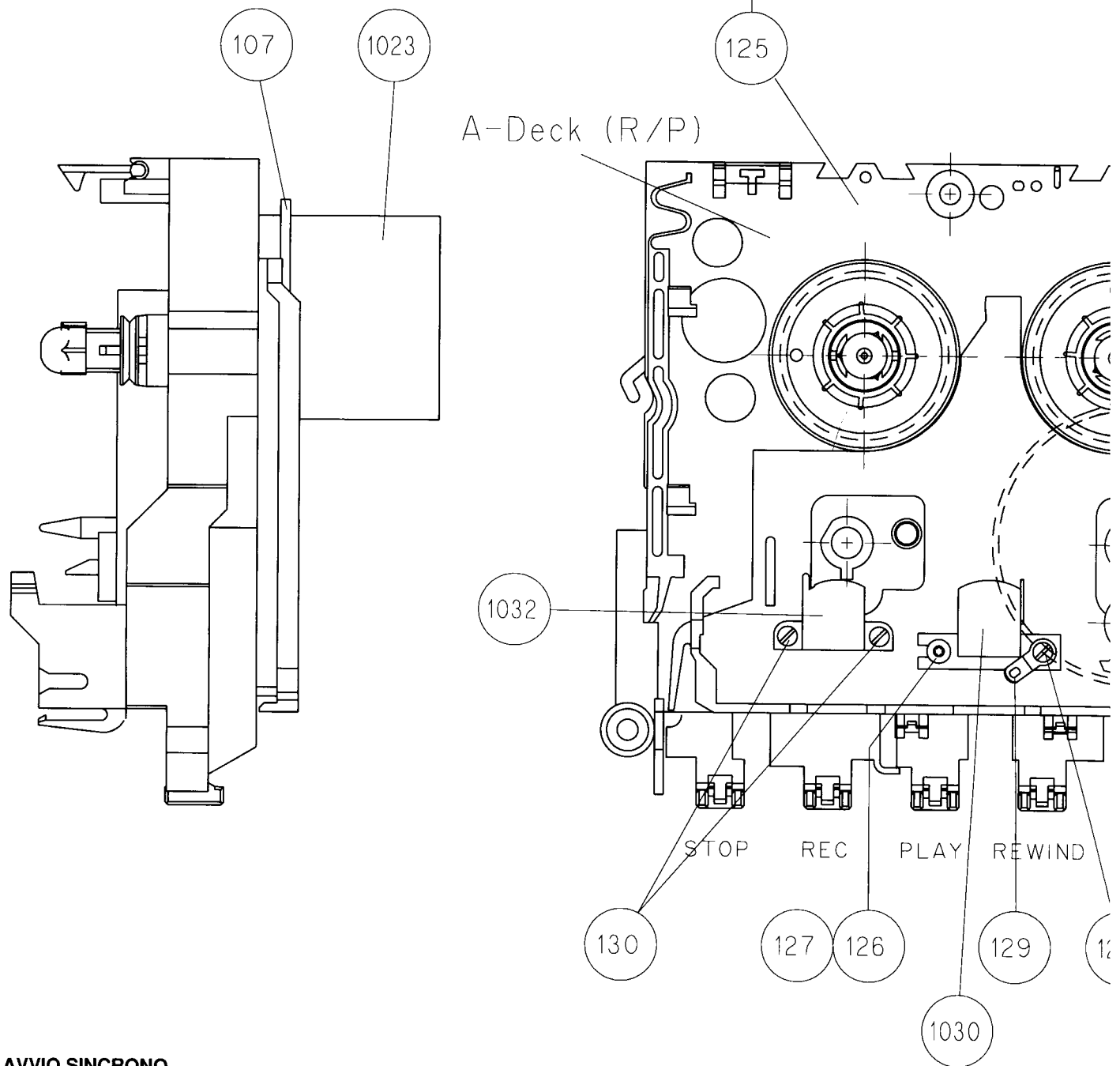

AVVIO SINCRONO

COPIATURA della cassetta nel riproduttore A sulla cassetta nel registratore/riproduttore B.

Ordine di comando:

- 1) premere il tasto **"PAUSE"** sul registratore/riproduttore B.
- 2) premere (una volta) il tasto **"REC"** sul registratore/riproduttore B.
- 3) premere il tasto **"PLAY"** sul riproduttore A.

Premendo il tasto **"PLAY"** sul riproduttore A verrà rilasciato il tasto **"PAUSE"** sul registratore/riproduttore B e quest'ultimo predisposto per la registrazione. La cassetta nel riproduttore A viene copiata sulla cassetta nel registratore/riproduttore B. Quando viene raggiunta la fine del nastro di una delle cassette, ambedue gli apparecchi vengono arrestati automaticamente.

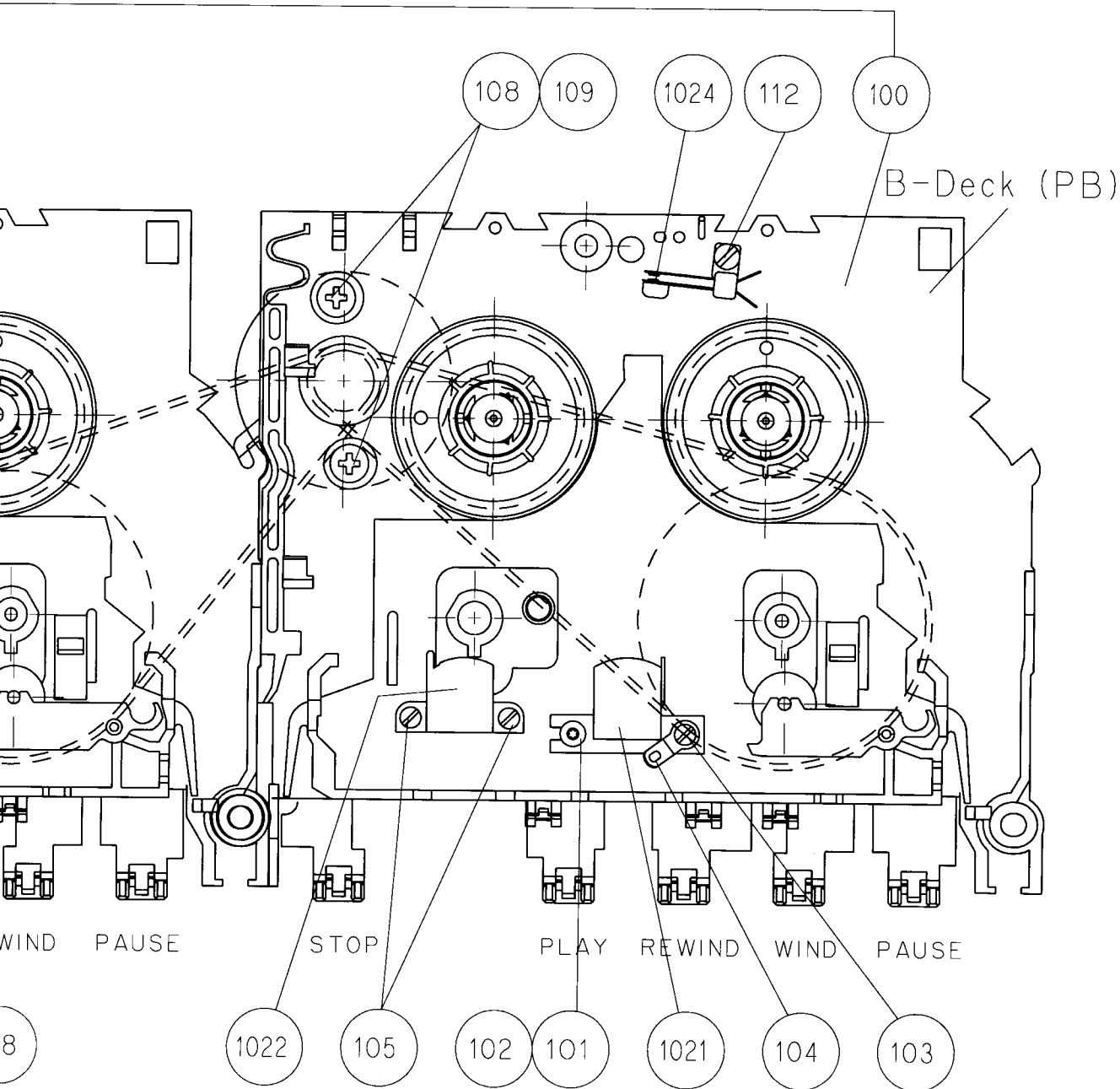

100	4822 691 10296	RN 0 assy
101	4822 492 51473	spring azimuth
107	4822 529 10254	damper,motor
108	4822 502 11866	screw,motor
125	4822 691 10296	RN 0 assy
126	4822 492 51473	spring,azimuth
1021	4822 249 10397	head,Rec/Pb
1022	4822 404 10685	head,dummy
1023	4822 361 21637	motor, MSI-5U2LWDR
1024	4822 271 30598	switch indication play
1030	4822 249 10397	head,Rec/Pb
1032	4822 249 20072	head,erase

General parts

7/67	4822 520 10718	bearing plate
38	4822 520 40134	ball, bearing
40	4822 402 10037	lever, pinch roller right
41/76	4822 528 70646	pinch roller
43	4822 404 10853	slide, key lock
58	4822 358 30929	drive belt RN0 S (long)
98	4822 358 30928	drive belt RN0 D (short)
402	4822 528 20676	take-up clutch assy

(pos. number refer to exploded view in General Documentation 4822 725 23763)

Only those parts of which a service code number is stated are service parts.

Service
Service
Service

Service Manual

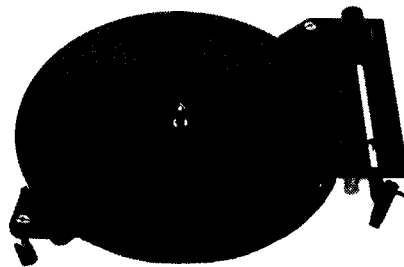

Specification

Power supply: 12V dc at 80mA
Wow and flutter: 0.25% JIS
0.35% DIN
Operating speed: 33 1/3 - 45rpm
Drive system: Belt drive with auto return

"Pour votre sécurité, ces documents
doivent être utilisés par des spécia-
listes agréés, seuls habilités à réparer
votre appareil en panne".



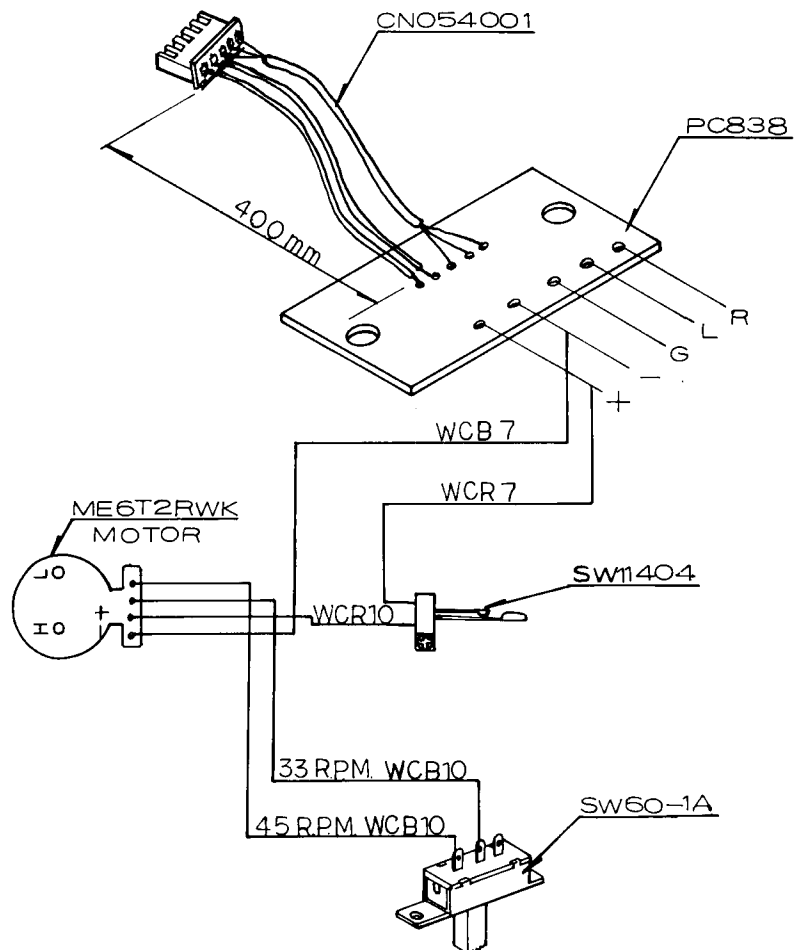
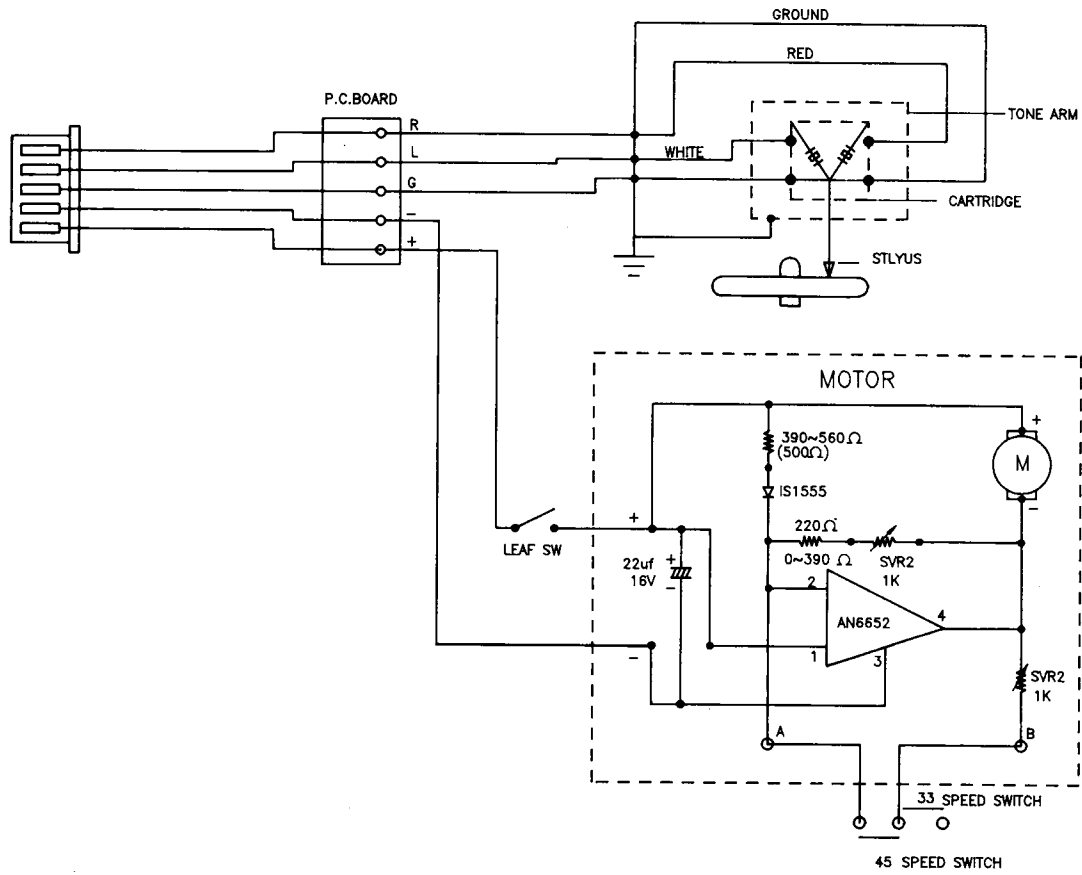

EXPLODED VIEW

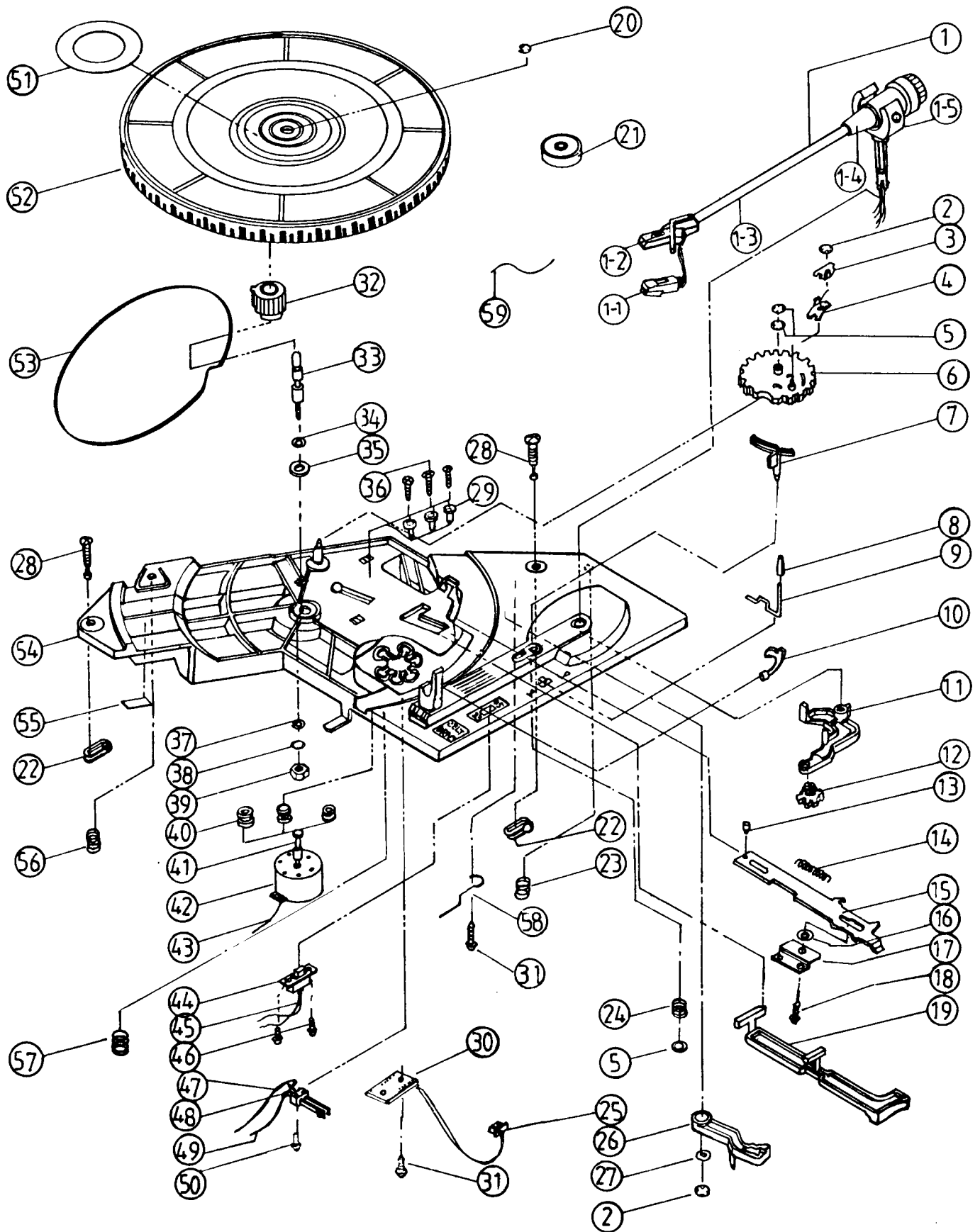

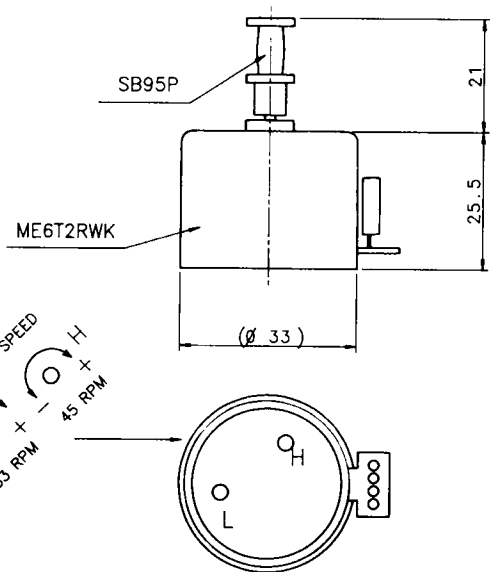

PLACEMENT OF BELT

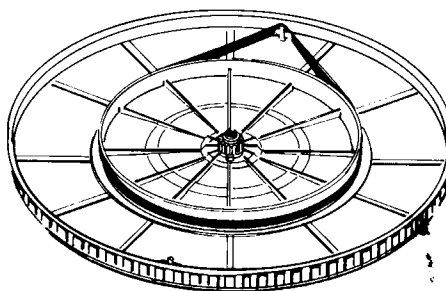

- 01 4822 251 70328
- 1-1 4822 251 30153
- 02 4822 530 80538
- 05 4822 530 80539
- 06 4822 522 33247

- 07 4822 402 61417
- 08 4822 462 41916
- 09 4822 402 61413
- 10 4822 402 61416
- 11 4822 402 61414

- 12 4822 402 61415
- 14 4822 492 71081
- 22 4822 492 71082
- 23 4822 492 71079
- 24 4822 492 71077

- 26 4822 466 93093
- 27 4822 532 52438
- 28 4822 502 13959
- 29 4822 532 52302
- 32 4822 522 33225

- 34 4822 532 52439
- 35 4822 532 52434
- 37 4822 532 52449
- 40 4822 462 71829
- 41 4822 528 50332

- 42 4822 361 21305
- 44 4822 277 21596
- 48 4822 276 13251
- 51 4822 460 20803
- 52 4822 528 10843

- 53 4822 358 31178
- 56 4822 492 71078
- 58 4822 492 71095

A : DELAY RETURN OPERATION
 B : ADVANCE RETURN OPERATION

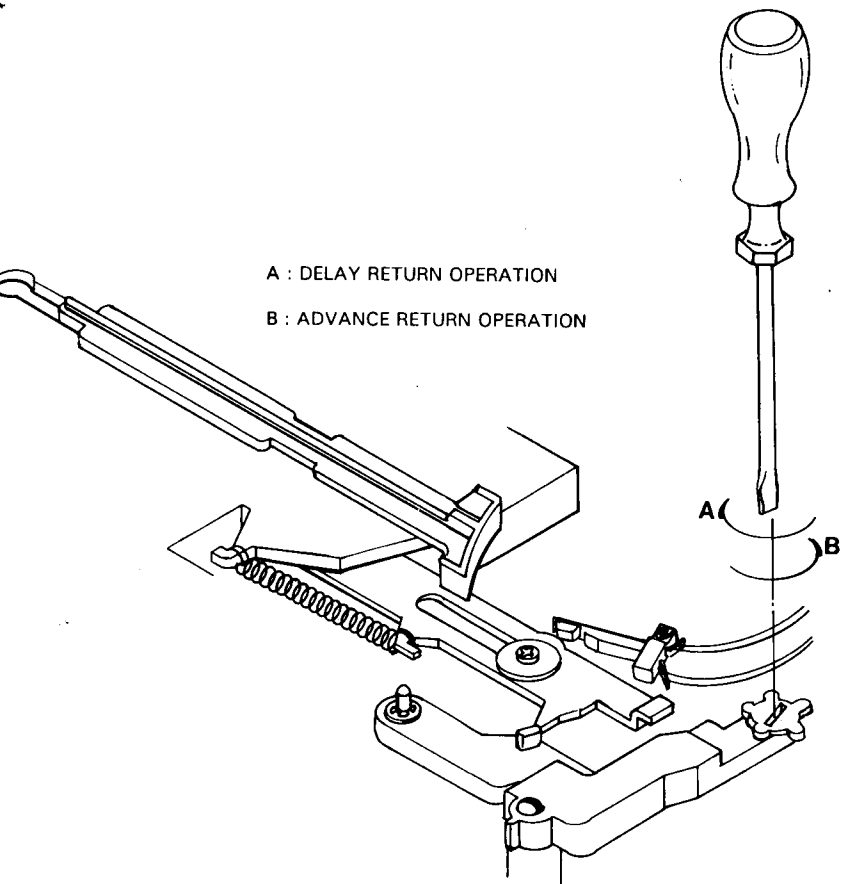

Note : Only the mentioned parts are normal service parts.